

2015-20XX CHEVY/GMC 2500-3500

REAR BUMPER INSTALLATION INSTRUCTIONS



SAFETY

Know safety, no injury. Know injury, no safety. ~Author Unknown

- **READ ALL SAFETY INSTRUCTIONS BEFORE INSTALLATION**
 - FOLLOW ALL INSTRUCTIONS FOR PROPER ASSEMBLY
 - WEAR APPROPRIATE EYE PROTECTION
 - EXERCISE CARE WHEN LIFTING COMPONENTS
 - USE APPROPRIATE TORQUE FOR BOLTS
 - BLUE THREAD LOCKING COMPOUND IS RECOMMENDED ON ALL BOLTS

 - SUGGESTED TORQUE VALUES FOR STEEL GRADE SAE 5 BOLTS

BOLT DIAMETER (INCH)	TREADS PER INCH	TORQUE (POUND-FEET)
1/4	20	7
5/16	18	14
3/8	16	25
7/16	14	40
1/2	13	60
9/16	12	88
5/8	11	120
3/4	10	200
7/8	9	302
1	8	466



2015-20XX CHEVY/GMC 2500-3500 REAR

I. PARTS LIST

ITEM NO.	QTY.	PART NUMBER	DESCRIPTION
1	2	307-07-0008	12V COOL WHITE LED 120DEG BLK
2	4	307-09-0135	BUTT SPLICE 22/16 RED, HEATSINK
3	4	316-01-0005	1.25" PLUG BT-FLUSH LDPE BLACK
4	1	443-01-0086	LICENSE PLATE MOUNTING KIT
5	1	601-56-2412	LEFT FRAME MOUNT WELDMENT
6	1	601-56-2413	RIGHT FRAME MOUNT WELDMENT
7	1	60K-56-0001	HARDWARE KIT #1
8	1	60K-56-0102	HARDWARE KIT #102
9	1	60P-56-0482	600-56-0482 POLISHED

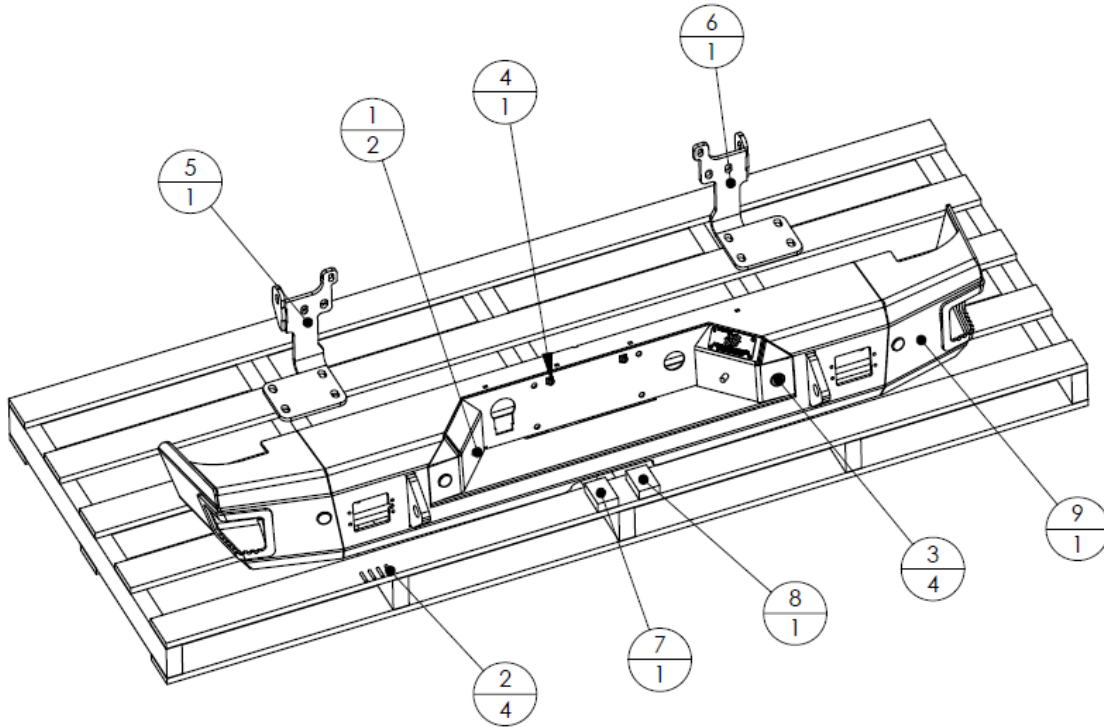



2015-20XX CHEVY/GMC 2500-3500 REAR

II. TOOL LIST

1. Basic set of tools
2. ¾" wrench
3. ¾" socket
4. Flathead screwdriver
5. 10mm socket
6. 13mm socket
7. 15mm socket
8. 18mm socket
9. 21mm socket
10. wire piers

III. REMOVAL OF OEM BUMPER

1. Using an 18mm socket, loosen all eight bolts attaching bed to frame.
2. Remove license plate.
3. Using a 13mm socket, remove two bolts attaching OEM bumper to OEM receiver hitch. Access them through the hole behind the license plate.



4. Unplug trailer connector, license plate, and sensor wiring harness. (if applicable)





2015-20XX CHEVY/GMC 2500-3500 REAR

- Using a 21mm socket, remove three bolts attaching OEM bumper to frame. One is accessed from the bottom of the truck. Using a 15mm socket, remove one bolt attaching OEM bumper to frame. (green arrow) (both sides)

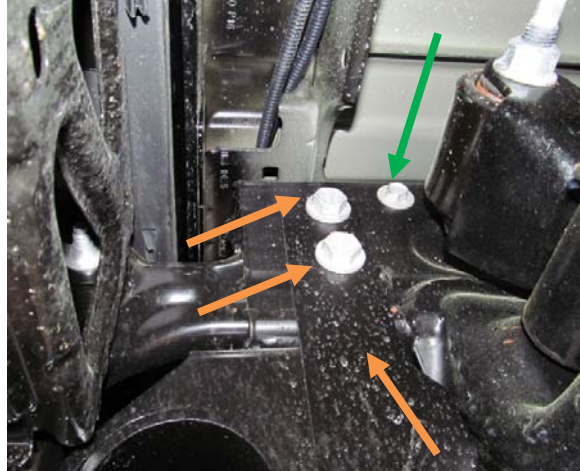

- Lift up on bed and remove OEM bumper by pulling straight out. (a few good friends or a cherry picker will be nice to have for this step)
- Remove OEM trailer plug by pushing in on clips.

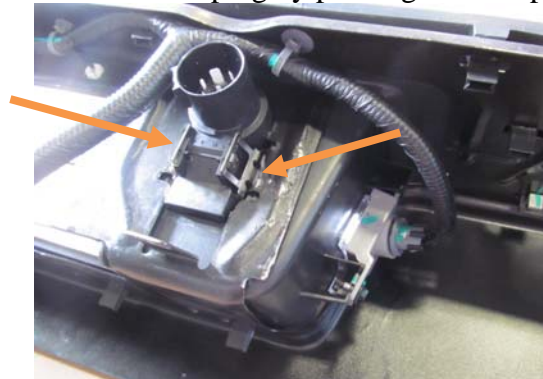

- Unplug OEM license plate lights.

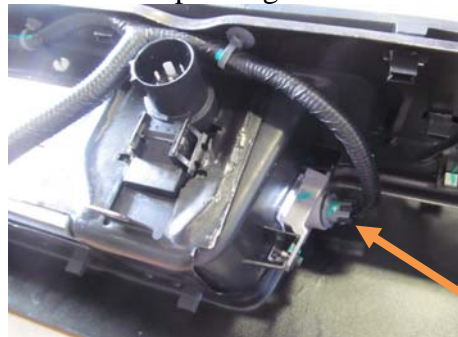



2015-20XX CHEVY/GMC 2500-3500 REAR

10. Remove OEM spare tire access housing. Pry back metal fingers on ring and remove plastic insert.

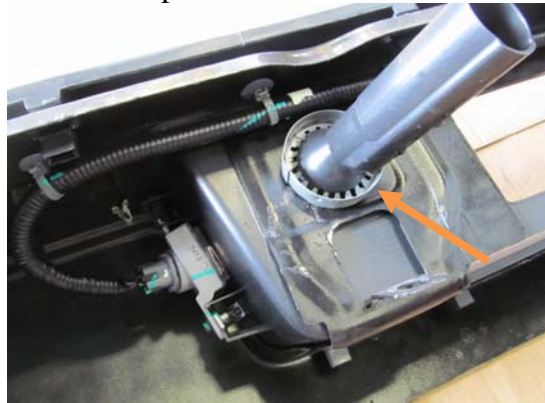

11. Remove OEM wiring harness from bumper. Be careful not to damage plastic tabs; they will be reused.
12. Remove sensors and grommets one at a time and place in Hammerhead bumper in corresponding holes.

IV. INSTALLATION OF HAMMERHEAD BUMPER

1. Install provided license plate lights in Hammerhead bumper.
2. Install OEM trailer plug in Hammerhead bumper. Ensure metal tabs are fully engaged on bumper surface. You may need to pull out on them gently.



3. Install OEM spare tire access housing.



4. Install OEM wiring harness on Hammerhead bumper and plug in and sensors. Use red butt connectors to attach provided license plate lights to OE wiring harness.
5. Install flush mount lights with provided hardware.



2015-20XX CHEVY/GMC 2500-3500 REAR

- Slide Hammerhead frame mounts all the way in frame and use 18mm socket to tighten all OEM bed bolts.
- Install Hammerhead Frame mount weldments as shown below. Use hardware kit #102 for this step. Use three 1/2"-13 x 2" bolts, six 1/2" flat washers, three 1/2" lock washers, and three 1/2" nuts for the larger bolt holes. Use one 3/8"-16 x 1.5" bolt, two 3/8" flat washers, one 3/8" lock washer, and one 3/8"-16 nut for the smaller forward most hole. These mounts will set the in and out adjustment of the bumper. (both sides)

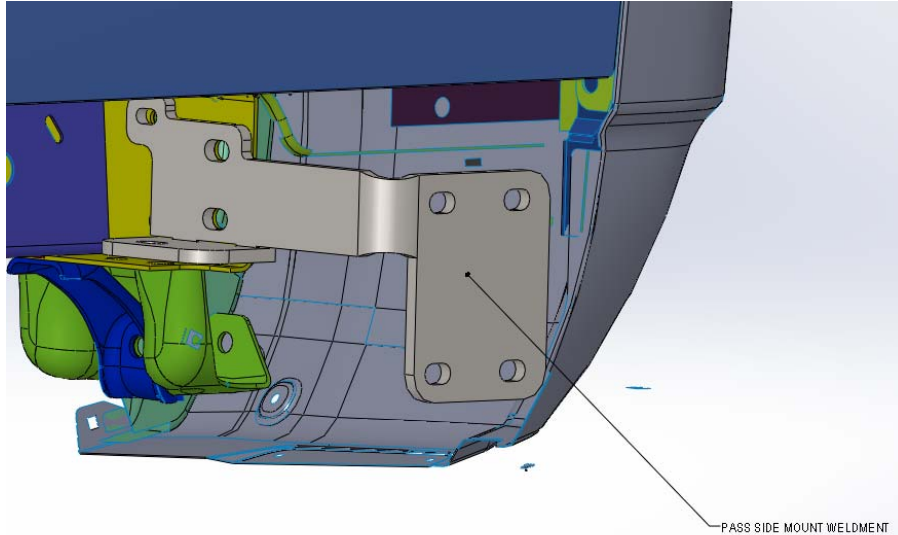



2015-20XX CHEVY/GMC 2500-3500 REAR

8. Install bumper on frame mounts using hardware kit # 1. Align bumper horizontally and vertically. Tighten nuts using $\frac{3}{4}$ " socket. Note: Open tailgate slowly to ensure minimum of $\frac{3}{8}$ " clearance below tailgate and minimum of $\frac{3}{8}$ " clearance from truck body.



Congratulations! Your product installation is now complete.
Thank you for your purchase.