

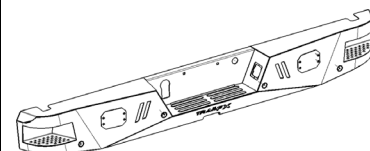

# Rear LD Bumper

Part No. RLDB008TI



Fits: **Current RAM 1500**



TO AVOID BEING SCRATCHED, PLEASE PROTECT THE SURFACE OF THE TAILGATE VENT COVER CAREFULLY.



REMOVE CONTENTS FROM BOX. VERIFY ALL PARTS ARE PRESENT.



READ INSTRUCTIONS CAREFULLY BEFORE STARTING INSTALLATION.

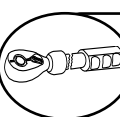

DO NOT OVER TORQUE. STANDARD OPERATING LOAD FOR TIGHTEN BODY MOUNT NUTS & BOLTS VARIES FROM 45 TO 65 FOOT POUND.



60-180 min



CUTTING NOT REQUIRED



DRILLING NOT REQUIRED



support@trailfx.com



1 866 638 4870



POLISHED STAINLESS STEEL - LIMITED LIFETIME  
POWDER COATED BLACK - 3 YEARS

### PARTS LIST:

| Qty | Part Description                      | Qty | Part Description                |
|-----|---------------------------------------|-----|---------------------------------|
| 1   | LD1 Rear Bumper Assembly              | 4   | 12mm x 37mm x 3mm Flat Washers  |
| 1   | Push in License Plate Light           | 4   | 12mm Lock Washers               |
| 2   | Plastic Plugs for license plate mount | 14  | 4mm x 10mm Button Head Bolts    |
| 6   | Retaining Clips                       | 4   | 4mm x 12mm x 1.0mm Flat Washers |
| 6   | 15.5mm x 25mm x 2mm Foam Washers      | 2   | 4mm Lock Washers                |
| 6   | 20mm x 2mm Foam Washers               | 2   | 4mm Hex Nuts                    |
| 6   | Sensor Hole Plugs                     | 1   | 4mm Wrench                      |
| 1   | Sensor Cover Kit                      | 1   | 2.5mm Wrench                    |
| 2   | 12mm Double Nut Plates                | 10  | Nylon Cable Ties 200mm          |
| 4   | 12-1.75mm x 35mm Hex Bolts            |     |                                 |

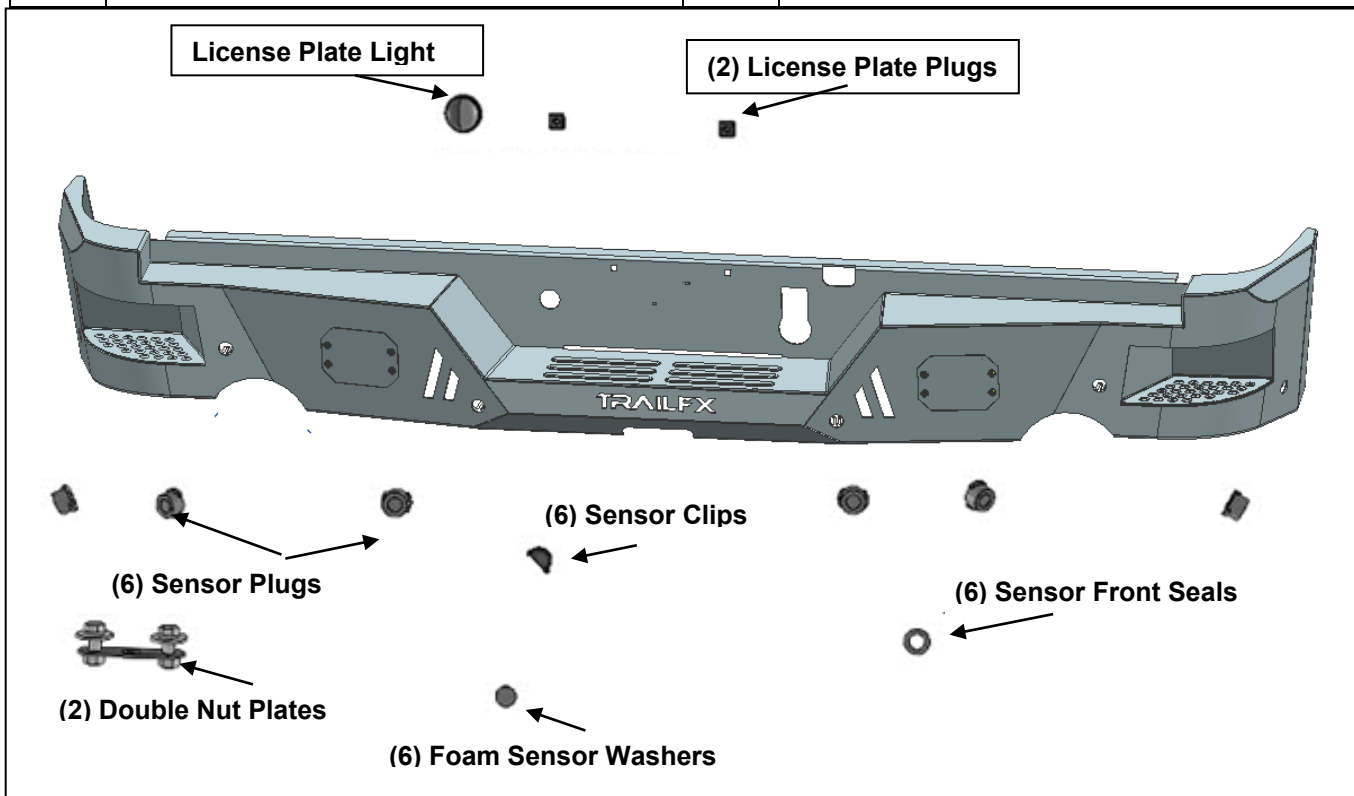

**PROCEDURE:**

**REMOVE CONTENTS FROM BOX. VERIFY ALL PARTS ARE PRESENT. READ INSTRUCTIONS CAREFULLY BEFORE STARTING INSTALLATION. BUMPER IS HEAVY, ASSISTANCE IS HIGHLY RECOMMENDED TO AVOID POSSIBLE INJURY OR DAMAGE TO THE VEHICLE. ALLOW EXHAUST TO COMPLETELY COOL BEFORE STARTING INSTALLATION.**

1. Start installation by unplugging the wiring harness leading to the rear bumper, **(Figure 1)**. Move harness away from the bumper.
2. Remove the license plate. Remove the (2) hex bolts behind rear license plate, **(Figure 2)**.
3. Place blocks or jack stands under the bumper to support it during bumper bolt removal. Once the bumper has been safely supported, remove the (4) factory hex nuts, (2 per side), and slide the rear bumper off of the end of the frame, **(Figures 3 & 4)**. **WARNING!** Assistance is required to hold the bumper in place during hardware removal and to prevent the bumper from falling. Move the bumper to a clean stable work surface.
4. Unplug and remove the wiring harness from the factory bumper. Remove the towing harness plug and sensors if equipped. Remove the remote antenna module from the back of the bumper if equipped.
5. Determine if the vehicle is equipped with bumper mounted sensors. **NOTE:** Depending on tow package, it may be necessary or easier to install sensors, (if equipped), or plugs before installing the Bumper.

**Models without bumper sensors:**

- a. Select the included (4) Rubber Plugs, **(Figure 5)**.
- b. From behind bumper, push plugs into sensor mounting holes, **(Figure 5)**. 4mm Screws have been provided to lock the plugs in the sleeve. Use is optional.

**Models with bumper mounted sensors:**

- a. Remove the silicone seal from the end of the sensor. Slide the included larger Sensor Seal over front of sensor, **(Figure 6)**.
  - b. Insert sensor with Seal into sensor mount, **(Figure 7)**.
  - c. Place Foam Washer over end of sensor. Push Sensor Retaining Clip into sensor mount and lock into mounting holes, **(Figure 7)**.
  - d. Repeat previous Steps to install remaining sensors.
  - e. Install wiring harness for sensors. **IMPORTANT:** Run the wiring harness above the Brackets to clear the exhaust tips. It may be necessary to remove a portion of the outer wiring cover on the harness to allow the harness to reach the sensors. Use the included plastic wire ties to secure the harness. It may be
  - f. **Optional:** Secure each sensor to the socket with (2) 4mm x 10mm Button Head Screws. **IMPORTANT:** Sensors fit snug in sockets. The 4mm Screws are used to apply slight pressure to lock the sensors in place. Tighten both screws evenly until they touch the sensor body only. Do not overtighten screws or damage to sensors will result.
6. Insert the License Plate Light into the lower hole in the Bumper. Attach Light to factory wiring harness. Insert the included (2) push-in plugs to attach the license plate to the Bumper, **(Figure 8)**.
  7. Insert the trailer plug into the opening in the Bumper if equipped, **(Figure 9)**.
  8. **LED light installation at ends of bumper**, (sold separately).
    - a. Insert light into opening and up to mounting slots. Check for clearance between front and back of light. If necessary, remove the screen from the back of the opening for additional clearance or access to light, **(Figure 10)**.
    - b. Follow the light manufacturer's instructions to attach (1) light to the center slot or (2) lights to the inner and outer slots in the top of the light opening.
    - c. Repeat the above steps for passenger side light installation.
    - d. Follow light manufacturer's instructions to properly wire the light.
    - e. **IMPORTANT:** On models with Dual Exhaust, screens must be removed before installing the Bumper if lights are to be installed.
  9. With assistance, position the LD1 Bumper up to the bumper brackets on the ends of the frame. Temporarily support the weight of the Bumper Assembly. **WARNING:** To avoid possible injury or damage to the vehicle, do not proceed until the Bumper is fully and safely supported.
  10. Line up the (2) mounting holes in the back of the driver side of the bumper with the brackets on the end of the frame. Slide (1) 12mm Double Nut Plate into place behind the mounting plate, **(Figure 11)**. Attach the Bumper to the frame and Nut Plate with (2) 12mm Hex Bolts, (2) 12mm Lock Washers and

(2) 12mm Flat Washers, (**Figures 11 & 12**). Leave hardware loose at this time. Repeat to attach the passenger/right side of the Bumper to the frame bracket.

11. Slowly open the tail gate and check for clearance. Level and adjust the LD1 Bumper and tighten all hardware.
12. Reattach the bumper wiring harness to the main wiring harness. Reuse factory hardware to attach license plate to plastic plugs in Bumper.
13. Do periodic inspections to the installation to make sure that all hardware is secure and tight.

**To protect your investment**, wax this product after installing. Regular waxing is recommended to add a protective layer over the finish. Do not use any type of polish or wax that may contain abrasives that could damage the finish. Mild soap may be used to clean the LD1 Bumper assembly.

### Driver/left side installation pictured

Wiring harness

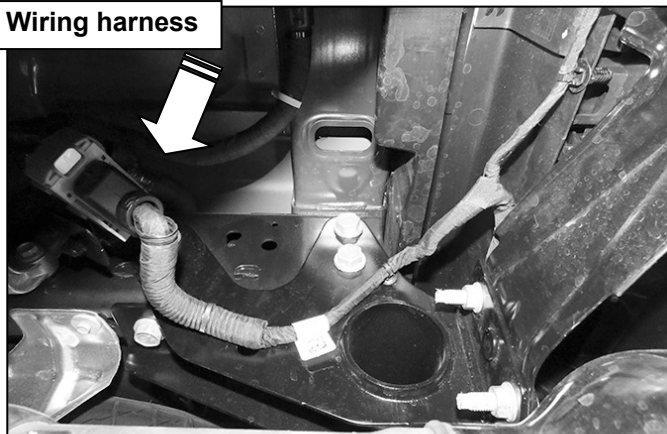

(Fig 1) Unplug wiring harness leading to bumper



(Fig 3) Remove hex nuts to remove bumper (arrow)

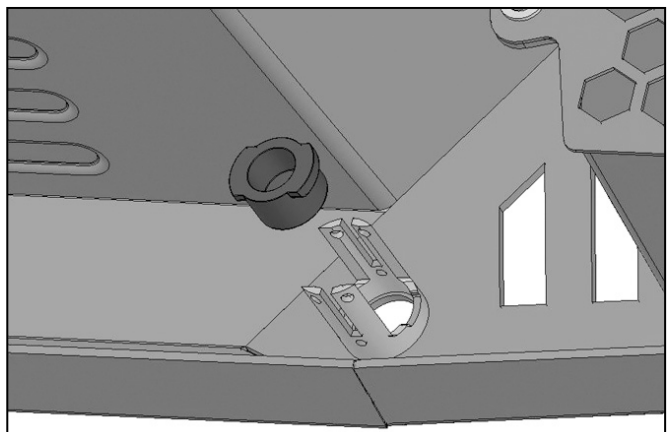

(Fig 5) Push Rubber Plug into sensor mounting sleeve. Use 4mm Screws to lock plugs in place.

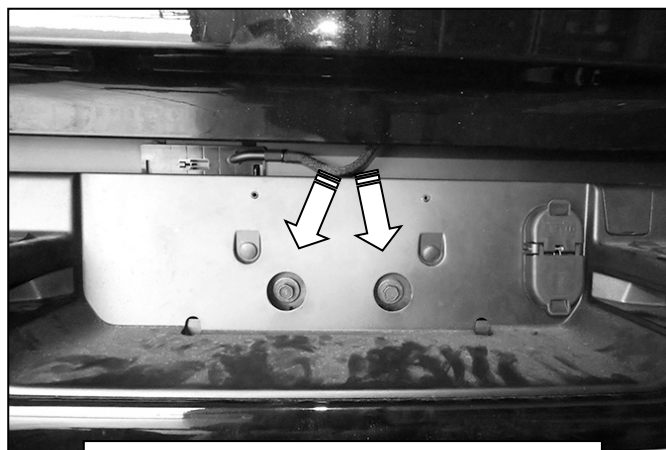

(Fig 2) Remove license plate to access and remove (2) hex bolts (arrows)

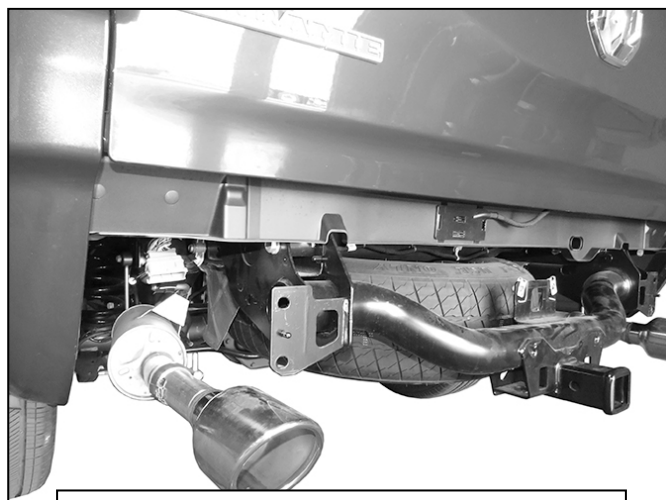

(Fig 4) Factory bumper assembly removed

**WARNING!** Do not remove bumper bolts unless the bumper is properly supported on blocks or stands or the bumper may fall.

Models with dual exhaust, allow exhaust to completely cool before starting installation

### Driver/left side installation pictured

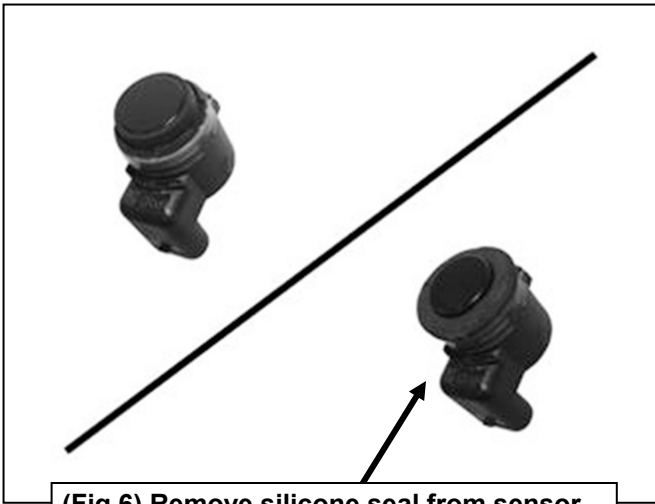

(Fig 6) Remove silicone seal from sensor. Slide large Seal over end of sensor (arrow)

**WARNING!** Do not crawl under bumper unless the bumper is properly supported on blocks or stands or the bumper may fall.

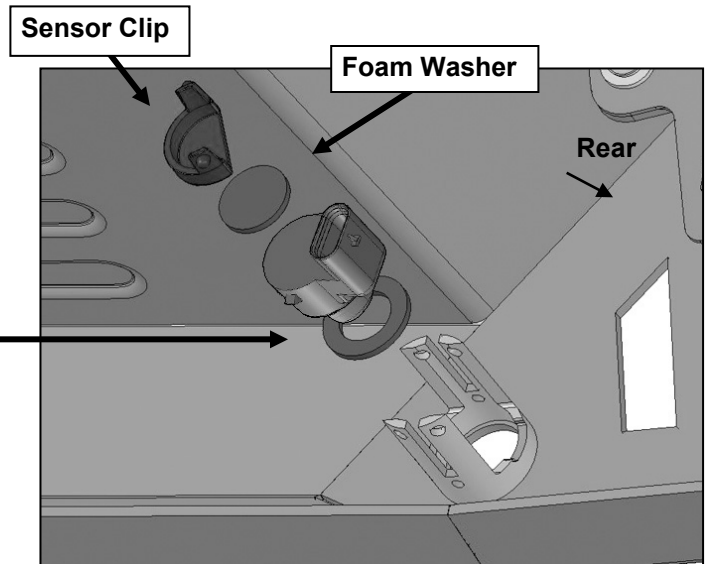

(Fig 7) Slide sensor into sleeve, insert Foam Washer and Clip to lock sensor in sleeve

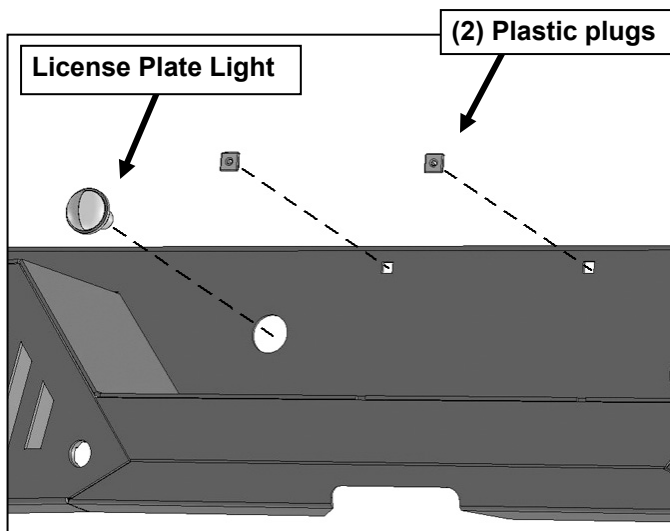

(Fig 8) Insert License Plate Light and Plastic Mounting Plugs

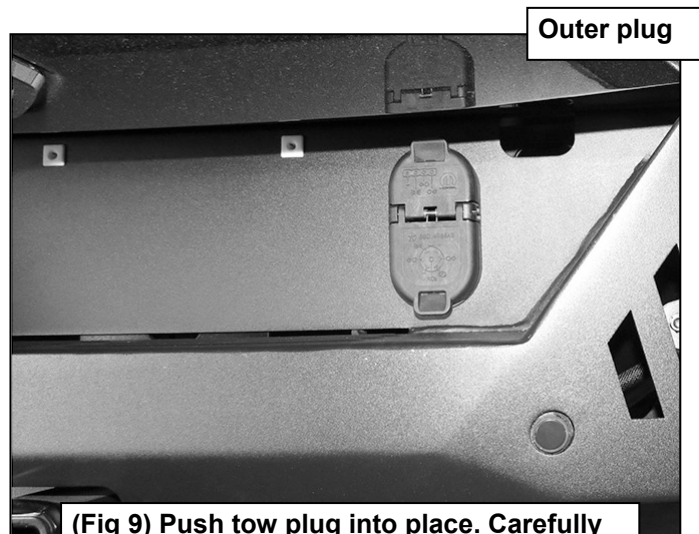

(Fig 9) Push tow plug into place. Carefully bend locking tab outward if necessary

### Driver/left side installation pictured

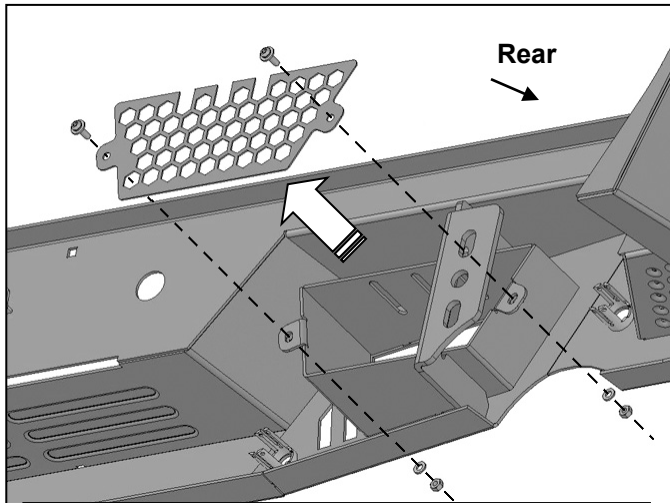

(Fig 10) Remove screens if necessary for additional clearance around or access to lights

**WARNING!** Do not crawl under bumper unless the bumper is properly supported on blocks or stands or the bumper may fall.

**IMPORTANT:** On models with dual exhaust, if bumper installation will include accessory lights, check for clearance around lights before installing bumper. Screens cannot be removed once bumper is installed.

- (2) 12mm Hex Bolts
- (2) 12mm Lock Washers
- (2) 12mm Flat Washers

12mm Double Nut Plate

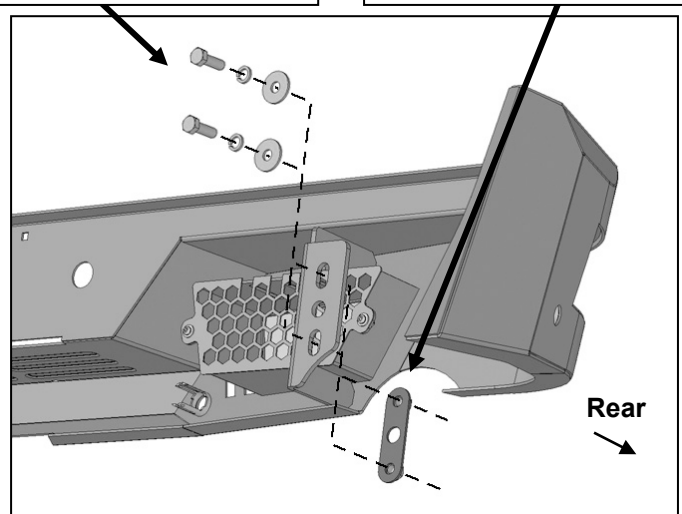

(Fig 11) Driver/left side illustrated

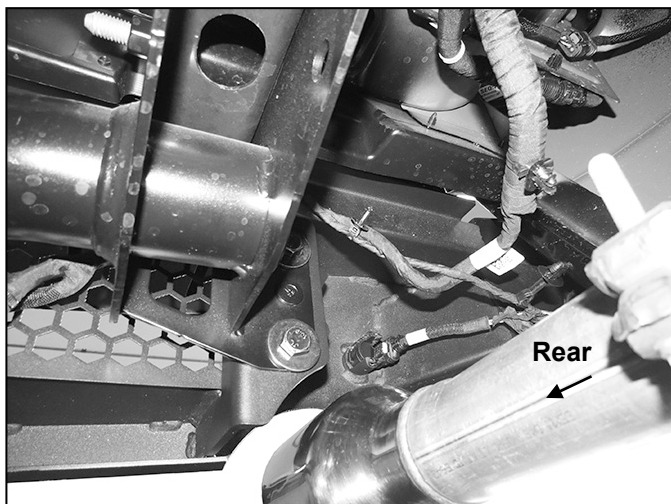

(Fig 12) Driver/left side pictured from behind bumper



| No. | Parts Identification                           |
|-----|--|
| 1   | Passenger / Right 'Rear' Bracket marked "PR"   |
| 2   | Driver / Left 'Rear' Bracket marked "DR"       |
| 3   | Passenger / Right 'Center' Bracket marked "PC" |
| 4   | Driver / Left 'Center' Bracket marked "DC"     |
| 5   | Passenger / Right 'Front' Bracket marked "PF"  |
| 6   | Driver / Left 'Front' Bracket marked "DF"      |

**Note:**

- > This guide is to identify the parts and not a reference for part count.
- > For part count, refer Parts List.
- > Product / Bracket image is representative and actual design may vary.

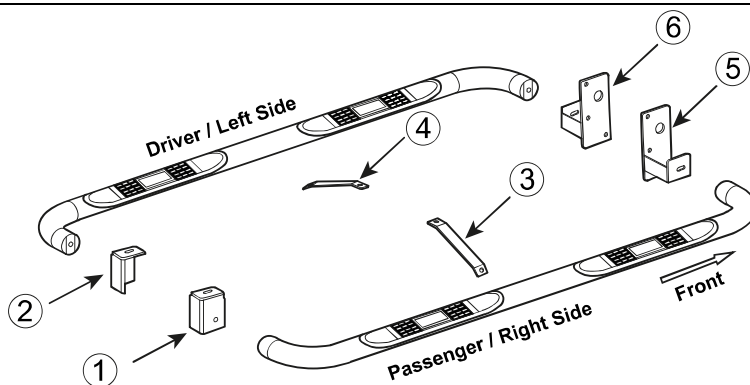
**PRODUCT CARE**

- Periodically check the product to ensure all fasteners are tight and components are intact.
- Regular waxing is recommended to protect the finish of the product.
- **Use ONLY Non-Abrasive automotive wax.** Use of any soap, polish or wax that contains an abrasive is detrimental and can scratch the finish leading to corrosion.
- Aluminum polish may be used to polish small scratches and scuffs for **Stainless Steel finish.**
- Mild soap may be used to clean the product for both **Stainless Steel and Black finish.**

**FAQ's****1. Hardware's are not of correct size.**

*In GMC / Chevrolet truck model 2006 & up, customer needs to reuse the factory body bolts to install the bracket. If your vehicle is not GMC / Chevrolet 2006 & up, ensure that holes are not partially covered with any plastic grommet or rust? If it is, remove the plastic grommet & rust from the thread holes & re-try the installation.*

**2. Mounting Bracket are not getting Installed properly.**

*In some cases Illustration images shown in Installation manual may not be the exactly same as per actual vehicle images ,also if Driver / Passenger side mounting brackets are very identical in the design, suggest referring Parts Identification guide to avoid fitment issue.*

**3. Products are thumping / rattling after installation.**

*Ensure that all required mounting brackets / hardware's are installed & tighten correctly. Suggest using white lithium / regular grease between the metal to metal contact surfaces.*

**4. Side Bar is not aligning with vehicle / Step Pads are not aligning with vehicle doors.**

*Side bar may be interchanged or mounting brackets are not installed at the correct position in the vehicle. Refer Parts identification guide.*

**5. Missing / Excess Hardware.**

*Recheck hardware count as per the part list.*

**6. Product not installing properly.**

*Ensure make model year, cab length and bed size of your vehicle is listed in the application. All installation steps are followed correctly.*

**Check out these other TrailFX Products!!**

www.TrailFX.com

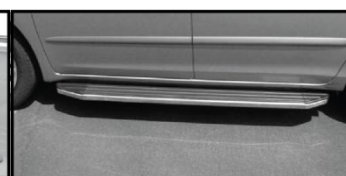
**BULL BAR****GRILLE GUARDS****BED RAILS****RUNNING BOARDS**

*Keystone Automotive Operations Inc. (KAO) warrants this product to be free of defects in material and workmanship at the time of purchase by the original retail consumer. KAO disclaims any other warranties, express or implied, including the warranty of fitness for a particular purpose or an intended use. If the product is found to be defective, KAO may replace or repair the product at our option, when the product is returned prepaid, with proof of purchase. Alteration to, improper installation, or misuse of this product voids the warranty. KAO's liability is limited to repair or replacement of products found to be defective, and specifically excludes liability for any incidental or consequential loss or damage.*