

2012-2015 TOYOTA TACOMA PRO SERIES REAR BUMPER PART #TC-2964

PARTS LIST:

1	Rear Pro Bumper	8	12-1.75mm x 40mm Hex Bolts
1	Driver/Left Mounting Bracket	4	12-1.25mm x 35mm Fine Thread Hex Bolts
1	Passenger/Right Mounting Bracket	4	12mm Lock Washers
2	Support Brackets	20	12mm x 24mm x 2.5mm Flat Washers
2	License Plate Plugs	8	12mm Nylon Lock Nuts

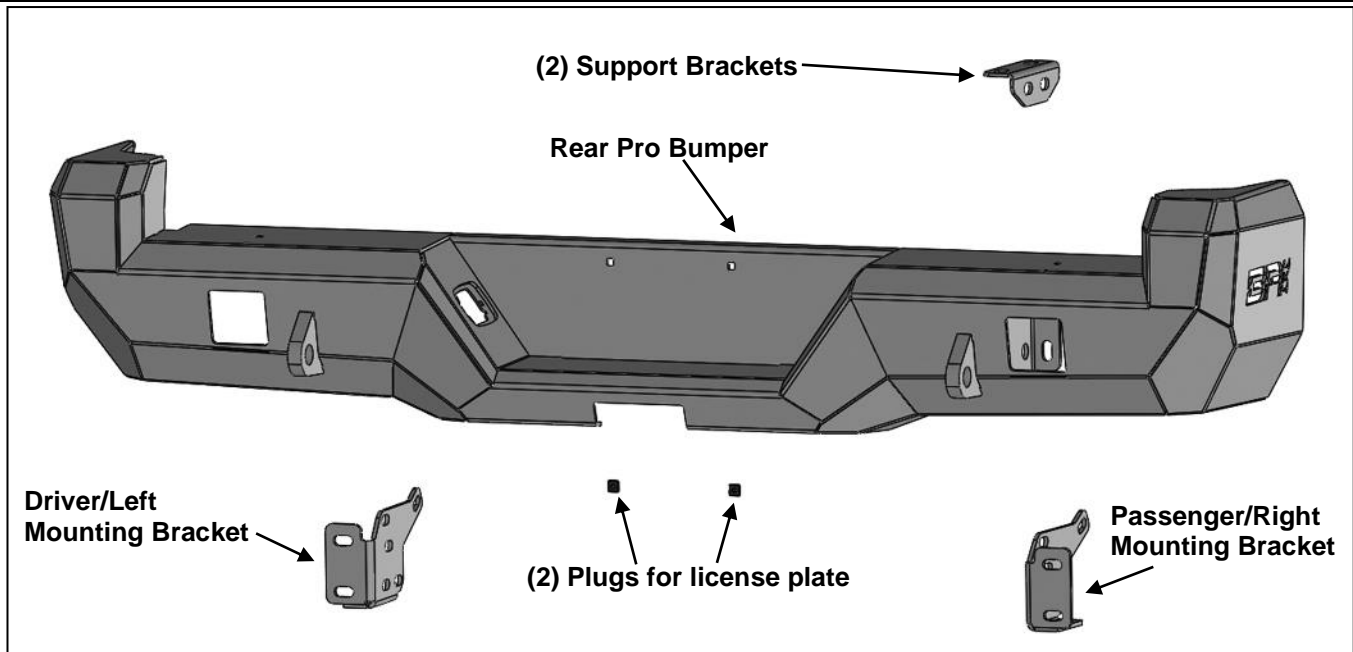

PROCEDURE:

REMOVE CONTENTS FROM BOX. VERIFY ALL PARTS ARE PRESENT. READ INSTRUCTIONS CAREFULLY BEFORE STARTING INSTALLATION. BUMPER IS HEAVY, ASSISTANCE IS RECOMMENDED TO AVOID POSSIBLE INJURY OR DAMAGE TO THE VEHICLE.

1. Remove the license plate from the bumper. Next, unplug the license plate lights and trailer plug, **(Figure 1)**. Disconnect all wiring harnesses leading to the rear bumper and move harnesses away from bumper.

2. **Determine if vehicle is equipped with factory receiver hitch**

Models without receiver hitch or with light duty aftermarket hitch:

- a. Place blocks or jack stands under the bumper to support it during mounting bolt removal. Once the bumper has been safely supported, remove the factory hex bolts, (3 per side), attaching the bumper brackets to the sides of the frame and slide the bumper assembly off of the vehicle. Do not remove hitch if equipped.

Models with factory receiver hitch and tow package:

- a. Remove the hardware attaching the bumper to the bottom of the receiver hitch, **(Figure 2)**.
- b. Remove the plastic cover from the top of the bumper, **(Figure 3)**. **NOTE:** Cover is attached at top, back and bottom by several plastic clips. Use a small flat blade screwdriver to carefully pry up the center pin to release clips.

- c. Place blocks or jack stands under the bumper to support it during mounting bolt removal. Once the bumper has been safely supported, remove the factory hardware attaching the bumper to the top and sides of the receiver hitch and remove the bumper, **(Figures 3—5)**. **NOTE:** Leave hitch attached to vehicle.
3. Release the clips securing the trailer plug and remove the plug. Remove license plate lights.
4. **Optional Light installation at ends of bumper** (light sold separately).
 - a. Follow the light manufacturer's instructions to attach each light to slot in the opening.
 - b. Repeat the previous step for remaining light installation.
 - c. Follow light manufacturer's instructions for adjustment and to properly wire the light to the vehicle electrical system after Bumper installation.

For Flush mount Cube Lights

- a. Place the light onto the square hole and line up the light to the hole. Mark the holes on the side of the light.
 - b. Drill the marked locations and attach the Cube Lights. Repeat the previous step for remaining light installation.
 - c. Repeat the previous step for remaining light installation.
 - d. Follow light manufacturer's instructions for adjustment and to properly wire the light to the vehicle electrical system after Bumper installation.
5. **Models without receiver hitch or with light duty aftermarket hitch, (models with factory HD receiver hitch and tow package, skip to Step 7):**
 - a. Select (1) Support Bracket, **(Figure 6)**. Attach the Bracket to the bottom of the frame with (2) 12mm Fine Thread Hex Bolts, (2) 12mm Lock Washers and (2) 12mm Flat Washers.
 - i. On models with aftermarket hitch, remove the (2) bolts attaching the driver/left side of hitch only, **(Figure 7)**.
 - ii. Insert Support Bracket between frame and hitch. Reinsert factory bolts or use (2) 12mm Fine Thread Hex Bolts, (2) 12mm Lock Washers and (2) 12mm Flat Washers to attach Bracket and hitch, **(Figure 7)**.
 - b. Do not fully tighten hardware at this time.
 - c. Repeat the previous Steps to attach (1) Support Bracket to the Passenger/Right side.
6. Select the Driver/Left Mounting Bracket.
Models without factory receiver hitch or with light duty aftermarket hitch:
 - a. Reuse (1) factory hex bolt to attach the top mounting hole in the driver/left Bracket to the side of the frame. **(Figures 8)**. Use (2) 12mm x 40mm Hex Bolts, (4) 12mm Flat Washers and (2) 12mm Nylon Lock Nuts to attach the Frame Bracket to the Support Bracket, **(Figure 8)**. Do not tighten hardware.
 - b. Repeat the previous Step to attach the Passenger/Right Bracket to the vehicle.**Models with factory receiver hitch and tow package**
 - a. Reuse the (5) factory hex bolts to attach the Driver/Left Bracket to the outside of the hitch and factory support bracket, **(Figure 9)**.
 - b. Repeat to attach the Passenger/Right Bracket to the vehicle.
7. With assistance, hold the Bumper assembly with Brackets up to the outside of the frame and/or hitch. Temporarily support the weight of the Bumper. **WARNING:** To avoid possible injury or damage to the vehicle, do not proceed until the bumper is fully and safely supported.
8. Attach the Bumper to the Mounting Brackets with (4) 12mm x 40mm Hex bolts, (8) 12mm Flat Washers and (4) 12mm Nylon Lock Nuts, **(Figure 10)**. Do not tighten hardware.

9. Level and adjust the bumper and fully tighten all hardware. Slowly open tailgate and check for clearance. Adjust as necessary.
10. Attach the wiring harness to the trailer plug. Secure the wiring harness to the frame as necessary.
11. Use the (2) push-in plugs to attach the license plate to the Bumper, **(Figure 11)**. Insert the License Plate Lights into the holes in the Bumper.
12. Connect the harness to the License Plate Lights.
13. Do periodic inspections to the installation to make sure that all hardware is secure and tight.

To protect your investment, Do not use any type of polish or wax that may contain abrasives that could damage the finish. Mild soap may be used to clean the Rear Bumper assembly.

Driver/left Side Installation Picture

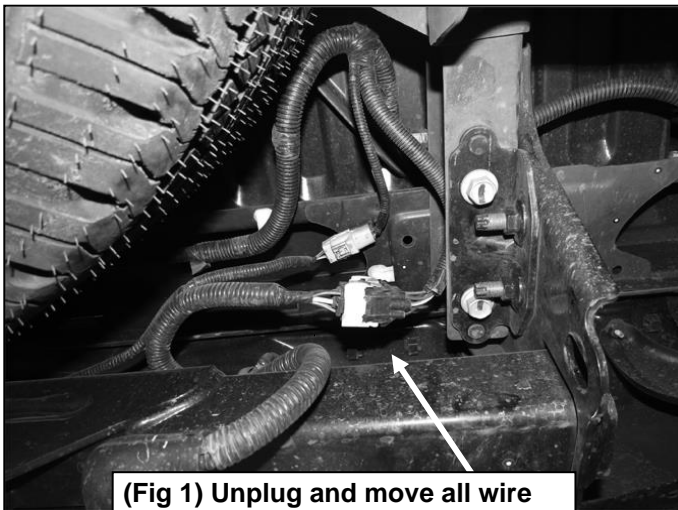

(Fig 1) Unplug and move all wire harnesses away from bumper

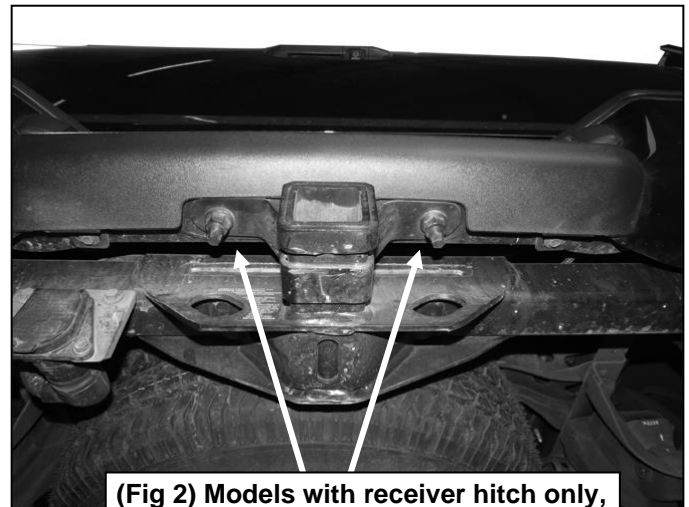

(Fig 2) Models with receiver hitch only, remove hex bolts attaching bumper to bottom of receiver hitch



(Fig 3) Models with receiver hitch only, remove plastic cover from top of bumper to access hex bolts attaching bumper to top of receiver hitch

WARNING! To avoid injury or damage to the vehicle, do not remove bumper bolts unless the bumper is properly supported on blocks and/or stands or the bumper may fall.

INSTALLATION INSTRUCTIONS

Driver/left Side Installation Pictured

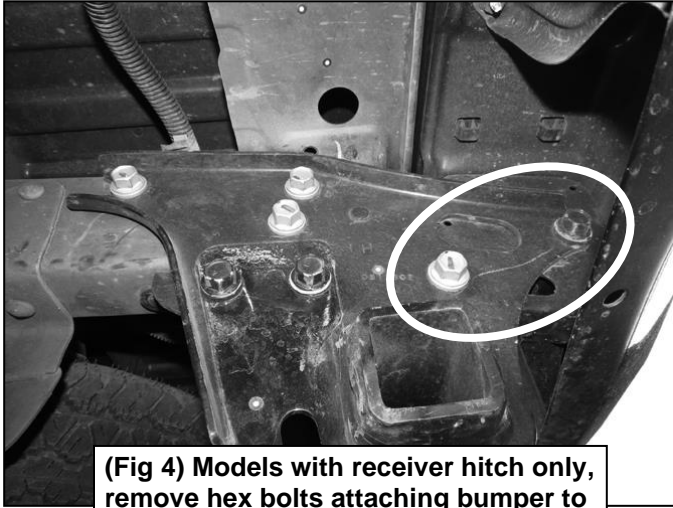

(Fig 4) Models with receiver hitch only, remove hex bolts attaching bumper to the side of the receiver hitch

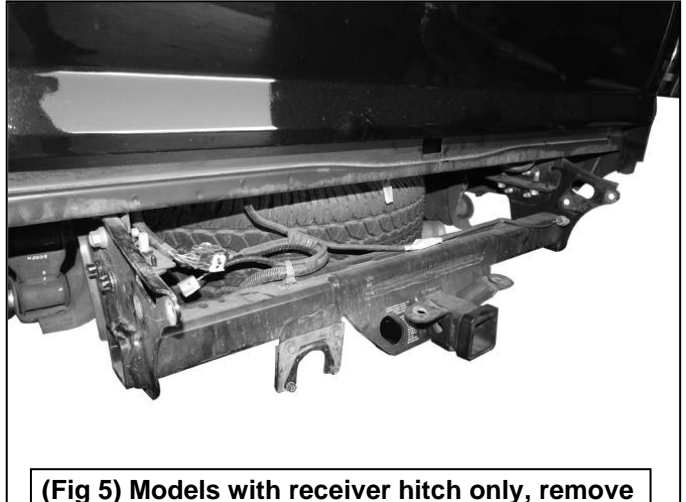

(Fig 5) Models with receiver hitch only, remove bumper but leave receiver hitch attached

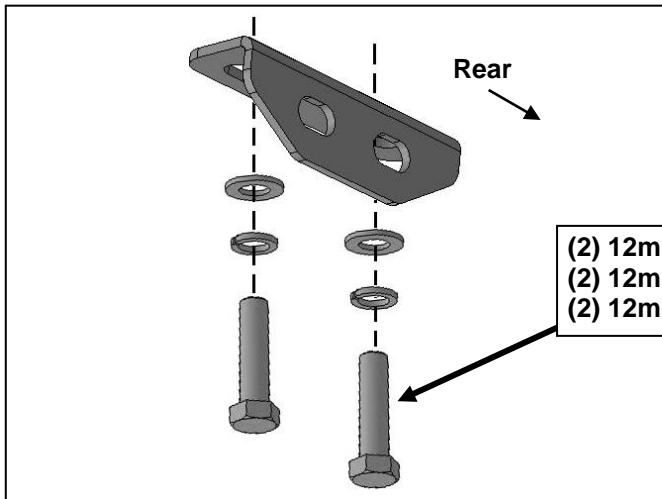

- (2) 12mm Fine Thread Hex Bolts
- (2) 12mm Lock Washers
- (2) 12mm Flat Washers

(Fig 6) Attach Support Brackets to frame (required on models without receiver hitch only)

WARNING! To avoid injury or damage to the vehicle, do not install bumper unless the bumper is properly supported on blocks and/or stands or the bumper may fall.



(Fig 7) Attach Support Brackets to bottom of frame. On models with aftermarket hitch, insert Bracket between bottom of frame and hitch

Driver/left Side Installation Pictured

