



**Assembly, Installation, Operation and  
Maintenance Instructions  
XV95 Recovery Winch**

**Part Number:  
WXV95B**

**120 minutes**

**Dealer / Installer:** Provide a copy of these instructions to the end user of this product. These instructions provide important operating and safety information for proper usage of this product. Demonstrate the proper use of the product with the end user. Have the end user demonstrate that they understand the proper use of the product.

**End User:** Read and follow all instructions included in this manual. Ask your Dealer / Installer for assistance if you do not understand the proper use of the product. Never remove any decals from the product. Failure to follow these instructions can result in injury or death.

**⚠ WARNING ⚠**

**APPLICATION: Universal for Truck or SUV (Designed for Bumpers and Mounting plates with 10" x 4.5" pattern)**

**⚠ WARNING ⚠**

**Observe safety precautions for personal safety and the safety of others.  
Improper equipment operation may cause personal injury and equipment damage.  
Never operate this winch if you are under 16 years of age.**

**Parts List:**

Description	Qty
XV95 Recovery Winch	1
Steel Cable, 94' x 8.3mm (Pre-spooled)	1
Roller Fairlead	1
Black Clevis Hook	1
Black Battery Cable Lead (5' 3/4")	1
Mounting Hardware Pack	1
Fairlead Hardware Pack	1
User Guide	1

**Tools Required**

Socket Wrench
Sockets - 19mm, 5/8
Adjustable Wrench / 3/4" 19mm Wrench
Large Flathead Screwdriver
Zip Ties

**Torque Specs**

Torque	Size
42.75 ft-lbs.	M10
65.25 ft-lbs.	M12

**Product Details:**

- High strength wire rope supported with roller fairlead and clevis hook designed to pull 9500 lbs safely and securely
- Wired Remote includes 12 feet lead to control winch from safe distance while recovering
- Meets IP67 standards for water and dust resistance

**Replacement Parts**

Description	Part Number
Motor Assembly	WXV001
Control Box	WXV002
Solenoid	WXV003
Remote Control	WXV004
Clevis Hook	WXV005
Battery Cable	WXV006
Wire Rope	WA006
Roller Fairlead	WA008
Hook Strap	WA010
Mounting Hardware	WA012

# Key Winch Components (WXV95B)

## Motor Housing

Houses the series wound 12V DC motor which drives the gear system and ultimately drives the drum.

## Control Box

Houses the heavy-duty solenoid which supplies power to the motor via remote control switch. Solenoid meets IP67 standards for water resistance.

## Clutch Shifter

Engages or disengages the gear drive system allowing operator to pull the rated load or free spool the rope.

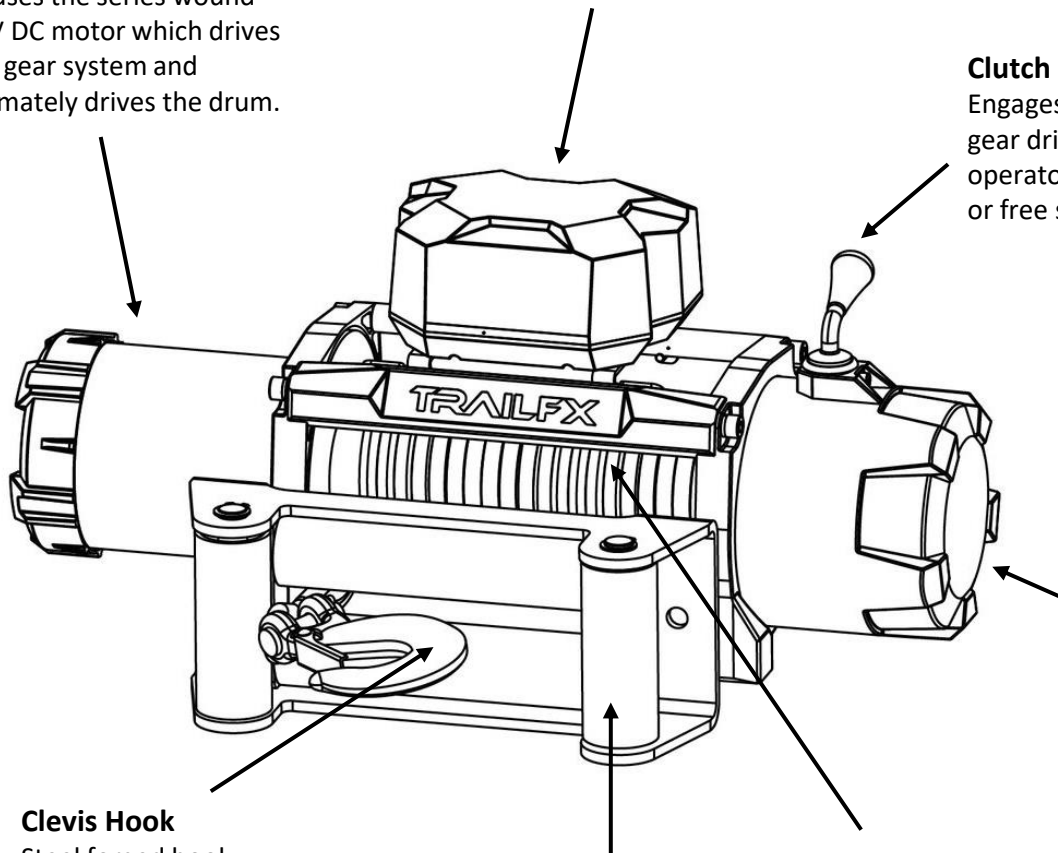

## Gear Housing

The gear housing covers the 3-stage planetary gear system that can be either engaged or disengaged by the operator.

## Clevis Hook

Steel forged hook connects cable to recovery point.

## Roller Fairlead

Guides the cable as it winds and unwinds around the drum.

## Steel Cable

The steel cable provides the recovery of the vehicle between the recovery anchor and the winch mounted to the vehicle.

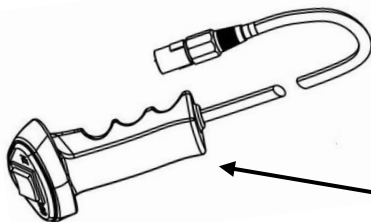

## Wired Remote Control

Allows the operator to control the winch from a safe distance.

# **Safety Precautions**

Read the following carefully before attempting to operate your winch and keep the instructions for future reference.

## **1. Dress properly:**

- Don't wear loose clothing or jewelry. They can be caught in moving parts.
- Wear proper winching gloves when handling winch rope. Do not handle rope with bare hands as broken strands can cause injuries.
- Non-skid footwear is recommended.

## **2. Keep a safe distance:**

- Ensure that all persons stand clear of winch rope and load during winch operation, 1.5 times of the rope length is recommended. If rope pulls loose or breaks under load, it can lash back and cause serious personal injury or death.
- Don't step over the rope.
- All visitors and spectators should be kept away from the recovery area.
- Always keep proper footing and balance.

## **3. Don't abuse the electrical cables:**

- Never carry your winch by the electrical cables or yank it to disconnect it from the receptacle.
- Keep electrical cables from heat, oil and sharp edges.

## **4. Don't overwork the winch:**

- If the motor becomes uncomfortably hot to touch, stop and let it cool for a few minutes.
- Shut off power to the winch if the motor stalls



**Don't exceed maximum line pull ratings shown in tables.  
Shock loads must not exceed these ratings**

## **5. Avoid unintentional starting:**

- Winch clutch should be disengaged when not in use and fully engaged when in use.

## **6. Check damaged parts:**

- Before using, you should check your winch carefully. Any part that is damaged should be properly repaired or replaced. Technical support and replacement parts may be obtained by contacting customer service as needed.

## **7. Repair your winch:**

- When repairing, use only identical replacement parts or it may cause considerable danger to the user. Replacement parts may be obtained from customer service.

## **8. Re-spool the rope:**

- Winching gloves must be worn while re-spooling. It is necessary to maintain slight load on the rope. Hold the rope with one hand and the remote-control switch with the other. Start as far back and in the center as you can. Walk up keeping load on the rope as the winch is powered in.
- Do not allow the rope to slip through your hand and do not approach the winch too closely.
- Turn off the winch and repeat the procedure until all the rope is spooled except 3 ft.
- Disconnect the remote-control switch and finish spooling in rope by rotating the drum by hand with clutch disengaged.
- On hidden winches, spool in rope under power but keep hands clear.

## Winch Operation Warnings

Read the following carefully before attempting to operate your winch and keep the instructions for future reference.

1. The uneven spooling of rope, while pulling a load, is not a problem, unless there is rope stacked up on one end of the drum. If this happens reverse the winch to relieve the load and move your anchor point further to the center of the vehicle. Once complete, you can unspool and rewind for a more balanced lay of the rope.
2. Store the remote-control switch inside your vehicle where it will not get damaged. Inspect it before you plug in.
3. When ready to begin spooling in, plug-in remote-control switch with clutch disengaged. Do not engage clutch with motor running.
4. Never connect the hook back to the rope as this causes rope damage. Always use a sling or chain of suitable strength.
5. Observe your winch while winching, if possible, while standing at a safe distance. Stop the winching process every couple of feet or so to assure the rope is not pulling up in one corner. Jamming the rope can break your winch.
6. Do not attach tow hook to winch mounting plate. It must be attached to vehicle frame.
7. The use of a snatch block will aid recovery operations by doubling the winch capacity, halving the winching speed and helps to maintain direct line pull to the center of the rollers. While double loading, the winch hook should be attached to the chassis of the vehicle.
8. Ensure rated "D-ring" or bow shackles are used in conjunction with an approved tree trunk protector to provide a safe anchor point.
9. When extending winch rope, ensure that at least eight wraps of rope remain on drum at all times. Failure to do this could result in the rope parting from the drum under load. Serious personal injury or property damage may result.



**10. All winches are provided with a red marking on the rope which identifies where (8) rope wraps remain on the winch drum. No recovery should be attempted beyond this marking or serious injury may occur.**

11. Since the maximum line pull is achieved on the first layer of the winch, it is desirable to pull off as much line as you can for heavy pulls. Doubling or tripling using snatch blocks can help. You must leave at least eight wraps minimum on the drum or see no red rope exposed!
12. Draping a heavy blanket or cable damper over the extended winch rope is recommended as it will dampen any back lash should a failure occur.
13. Neat, tight spooling avoids rope binding, which is caused when a load is applied and the rope is pinched between the others. If this happens, alternatively power the winch in and out. Do not attempt to work a bound rope under load, free by hand.
14. Apply blocks to wheels when vehicles are on an incline.
15. Battery:
  - Be sure that the battery is in good condition.
  - Avoid contact with battery acid or other contaminants.
  - Always wear eye protection when working around a battery.
  - Have the engine running when using the winch, to avoid rapid degradation of the battery.

# Winch Operation Warnings Continued

## 16. Winch rope:

- Be sure that the rope is in good condition and is attached properly.
- Do not use the winch if rope is frayed.
- Do not move the vehicle to pull a load.
- Do not replace the rope with a rope of lesser strength.
- The life of the rope is directly related to the use and care it receives. Following its first and subsequent uses, a rope must be wound onto the drum under a load of at least 500lbs (230kgs) or the outer wraps will draw into the inner wraps and severely damage the rope during the winching. The first winch use should be a familiarization run while in a relaxed, non-recovery situation. Spool out the rope until the red rope mark appears (about 8 wraps remaining on the drum), and then rewind the rope on the drum under a load of 500lbs (230kgs) or more.
- When the rope is replaced, be sure to apply a thread locking compound to the rope clamp thread. Tighten the clamp screw properly but do not over tighten. The thread locking compound will prevent loosening of the screw in arduous conditions.

**17. Do not attempt to exceed the pulling limits of the winch.**



**18. Do not drive your vehicle to assist the winch in any way. Vehicle movement in combination with winch operation may overload the rope, the winch itself or cause damaging shock loads!**

**19. Shock loads when winching are dangerous! A shock load occurs when an increase force is suddenly applied to the rope. A vehicle rolling back on a slack rope may induce a damaging shock load.**

20. The winch shown in this manual are solely for vehicle and non-industrial applications.

21. Do not use winch in hoisting applications due to required hoist safety factors and features.

22. Do not use the winch to lift, support or otherwise transport personnel.

## Installation

### Mounting your Winch

1. The winch is to be mounted into a suitable sized mounting frame using the 4-point foot mounting system in either a horizontal or vertical plane.

- It's very important that the winch be mounted on a flat surface so that the three sections (motor, rope drum and gear housing) are properly aligned.
- The fitment of winches and/or a frontal protection system may affect the triggering of SRS air bags. Check that the mounting system has been tested and approved for winch fitment in the air bag equipped.
- Always verify area is clear of fuel lines, fuel tank, brake lines, electrical wires, etc. when drilling or installing winch, bumpers and mounting plates.

2. Winch mounting frames and/or frontal protection systems are suggested to suit most popular vehicle. Winch frames are packaged with detailed fitting instructions.

3. The winch should be secured to the mounting with the hardware included with your winch.

4. The fairlead is to be mounted to guide the rope onto the drum evenly.

**Make sure all mounting hardware is at proper torque rating.**

# Measurement Specifications – WXV95B

All dimensions in inches

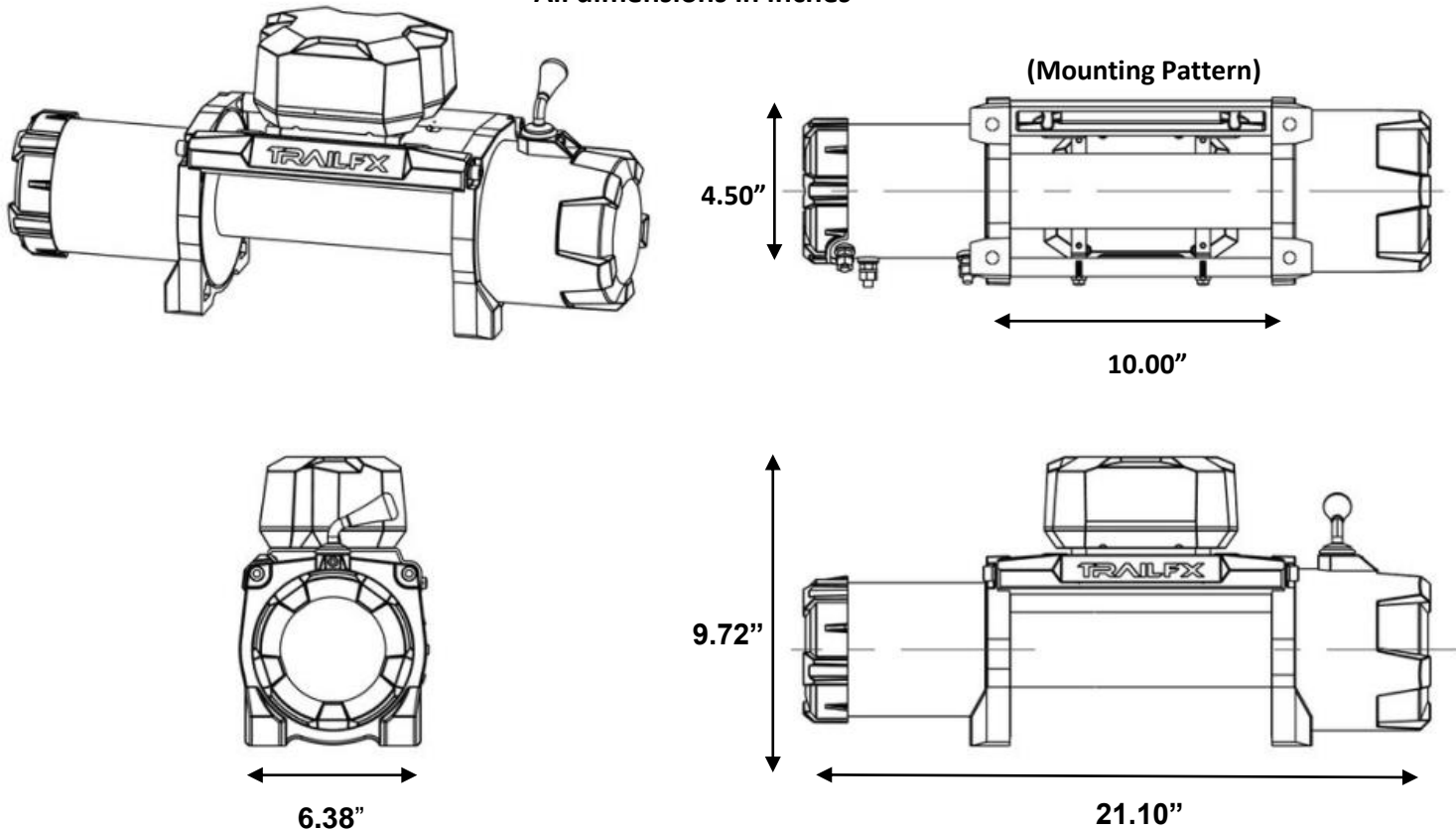

# Electrical Connection – WXV95B

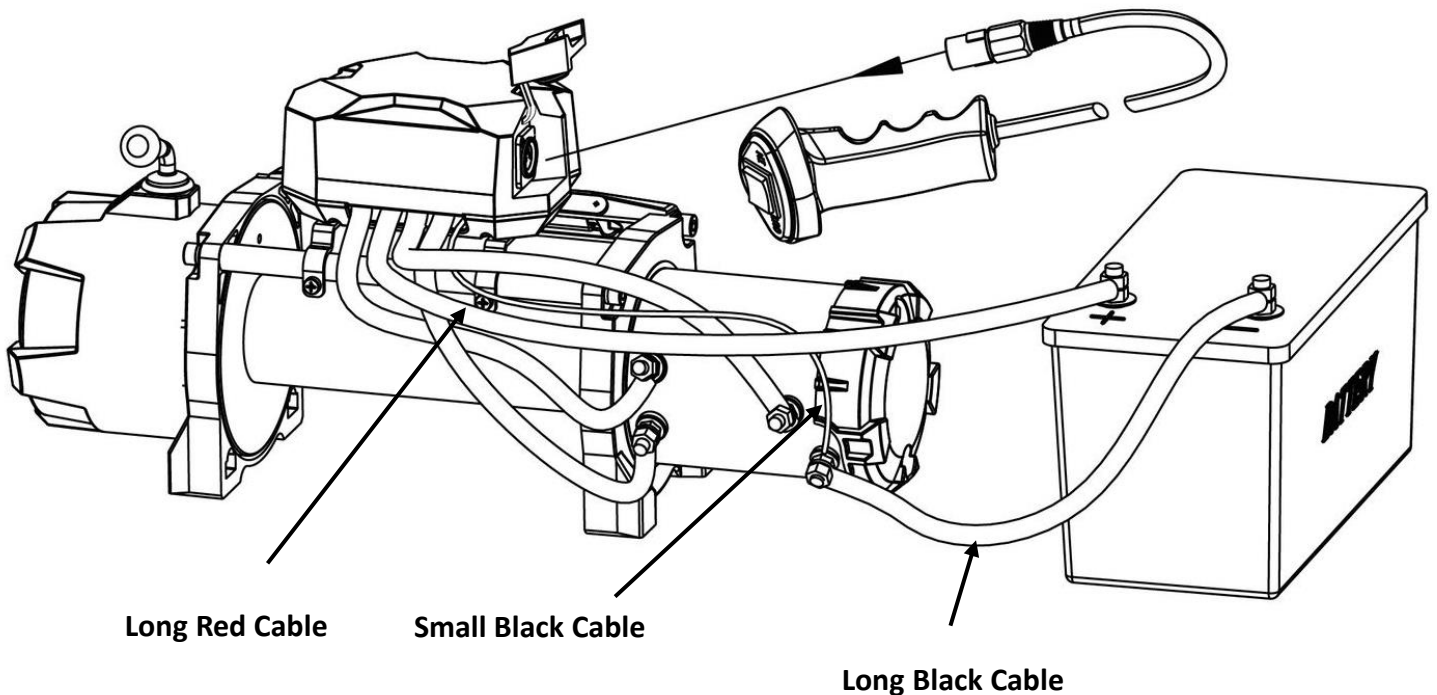

# **Electrical Connection**

For normal self-recovery work, your existing electrical system is adequate. A fully charged battery and proper connections are essential. Run the vehicle engine during winch operation to keep battery charged.

Pay close attention to proper electrical cable connection as follows:

## **Winch Electrical Connection**

1. Red Cable 'B' connects to the red terminal 'B' on the winch motor.
2. Black Cable with Yellow Boot 'C' connects to the yellow terminal 'C' on the motor.
3. Black Cable with Black Boot 'D' connects to the black terminal 'D' on the motor.

## **Winch Connection to Battery**

1. Long RED cable from winch control pack connects to the positive (+) terminal of the battery.
2. Long BLACK cable (supplied separately from winch) connects from terminal 'A' and the opposite end connecting to the negative (-) terminal of the battery.

## **Important Notes**

1. Your battery must be kept in good condition.
2. Be sure battery cables are not drawn tight across any surfaces, which could cause damage.
3. Corrosion on electrical connections will reduce performance or may cause a short.
4. Clean all connections especially in remote control switch and receptacle.
5. In salty environments use a silicone sealer to protect from corrosion.
6. Index the heads of the plate studs into the keyhole slots on the back of the winch.
7. If electrical cables are closer to hot surface, use the heat protection sleeve to prevent damage.

## **Remote Control Operation**

1. Plug remote control end into the connection port on the left of the control box (on top of winch).
2. Be sure the clutch lever is engaged when using under load.
3. To spool wire rope from the drum, press the "out" button on the remote. To spool wire rope in, press the "in" button.

# Winch Operation

## Suggestion

The best way to get acquainted with how your winch operates is to make a few test runs before you need to use it. Plan your test in advance. Remember you can hear your winch as well as you can see it operate. Understand the sound of a light steady pull, a heavy pull, and sounds caused by load jerking or shifting. Soon you will gain confidence in operating your winch and its use will become second nature to you.

## Operating

1. Ensure the vehicle is secure by applying the parking brake or chocking the wheels.
2. Pull out the rope to the desired length and connect to an anchor point.  
The winch clutch allows rapid uncoiling of the rope for hooking onto the load or anchor point. The shifter tab located on the gear housing of the winch operates the clutch as follows:
  - a) To disengage the clutch, move the clutch shifter tab into the “OUT or FREE” position. Rope may now be free spooled off the drum.
  - b) To engage the clutch, move the clutch shifter tab into the “IN or LOCKED” position. The winch is now ready for pulling.
3. Recheck all rope rigging before proceeding.
4. Plug in the winch remote control. It is recommended that the winching operation takes place from the driver’s position to ensure safe operation.
5. To commence winching operation, start vehicle engine, select neutral in transmission, maintain engine speed at idle.
6. Operate the remote-control switch to IN or OUT until the vehicle has been retrieved. Regularly check the winch to ensure rope is winding onto the drum evenly.

### **MUST READ THIS**

1. Never winch with your vehicle in gear which would damage your vehicle’s transmission.
2. Never wrap the rope around the object and hook onto the rope itself. This can cause damage to the object being pulled and kink or fray the rope.
3. Keep hands, clothing, hair and jewelry clear of the drum area and rope when winching.
4. Never use the winch if the rope is frayed, kinked or damaged.
5. Never allow anyone to stand near the rope or in line with the rope behind the winch while it is under power. If the rope should slip or break, it can suddenly whip back towards the winch, causing a hazard for anyone in the area. Always stand safely to the side while winding.
6. Do not leave the remote control plugged in when not in use.

### **CHECK THE WINCH CAREFULLY AND THOROUGHLY BEFORE OPERATING!**



# Maintenance

It is highly recommended that the winch be used regularly (once a month). Simply power the rope out 50 ft., free spool 15 ft. and then power back in. This will keep all components in good working condition so that the winch can be relied on when needed. Contact your authorized outlet for technical assistance and repairs.

Trouble Shooting		
Symptom	Possible Cause	Suggested Remedy
Motor does not turn on	Switch Assembly not connected properly. Drained Remote Battery (in case of wireless Remote).	Insert switch Assembly firmly to the connector.  Replace Batteries as per the instructions in page no. 9.
	Loose battery cable.	Tighten nuts on cable connectors.
	Solenoid malfunctioning.	Tap solenoid to free contact, applying 12 volts to coil terminal directly. Make an audible clicking when activating.
	Defective switch Assembly.	Replace switch Assembly.
	Defective motor.	Check for voltage at armature port with switch pressed. If voltage is present, replace motor.
	Water has entered motor.	Drain and dry, Run in short bursts without load until completely dry.
Motor runs too hot.	Long period of operation.	Let winch cool down periodically.
Motor runs slowly or without normal power.	Battery runs down.	Recharge battery by running vehicle.
	Insufficient current or voltage.	Clean, tighten or replace the connector.
Motor runs but rope drum does not turn.	Clutch not engaged.	Turn clutch into IN position, if that does not work, ask a qualified technician to check and repair.
Motor runs in one direction only.	Defective or stuck solenoid.	Tap solenoid to free contacts. Repair or replace solenoid.
	Defective switch Assembly.	Replace switch Assembly.

## Lubrication

All moving parts in the winch are permanently lubricated with high temperature lithium grease at the time of assembly. Lubricate wire rope periodically using light penetrating oil. Inspect for broken strands and replace if necessary. If the rope becomes worn or damaged it must be replaced.

## Rope Installation

Unwind the new rope by rolling it along the ground, to prevent kinking. Remove old rope and observe the way it is attached to the rope drum flange. Install new rope in the same way as the old rope is attached to the rope drum flange.

 **Replace rope with the exact diameter, length and strength as that of the existing rope.**

# Winch Specifications

<b>XV95 Winch Specifications</b>	
TrailFX Part No.	<b>WXV95B</b>
Rated Line Pull	9,500 lb (4309 kg)
Motor	5.7 hp (5.7 CV)
Remote Control	Wired Remote with 12 ft (3.7 m) lead
Electrical Control	450 A Heavy-Duty Solenoid
IP Rating	IP67
Gear Train	3 - Stage Planetary
Gear Ratio	218 : 1
Clutch Type	Manual - Sliding Ring Gear
Brake	Automatic Full Load
Drum Size	2.5" (63.5 mm)
Rope	Steel Cable, 8.3 mm x 94 ft
Fair Lead	4 Way Roller
Recommended Battery	650 CCA minimum
Weight	88 lb (40 kg)
Mounting Pattern	10 in x 4.5 in

<b>Winch Performance</b> (Based on first layer of drum)		
<b>Line Pull (lbs)</b>	<b>Line Speed ft / min</b>	<b>Motor Current Amps</b>
0	32	75
2000	20	140
4000	15	210
6000	11	260
8000	9	310
9500	6	370

<b>Line Pull (Layer)</b>	<b>Line Pull by Layer (lbs)</b>	<b>Rope Capacity (Ft)</b>
1	9500	16
2	8100	42
3	6900	72
4	6000	94

Motor rating based on input power.

Winch meets IP67 Specification for water ingress/resistance.



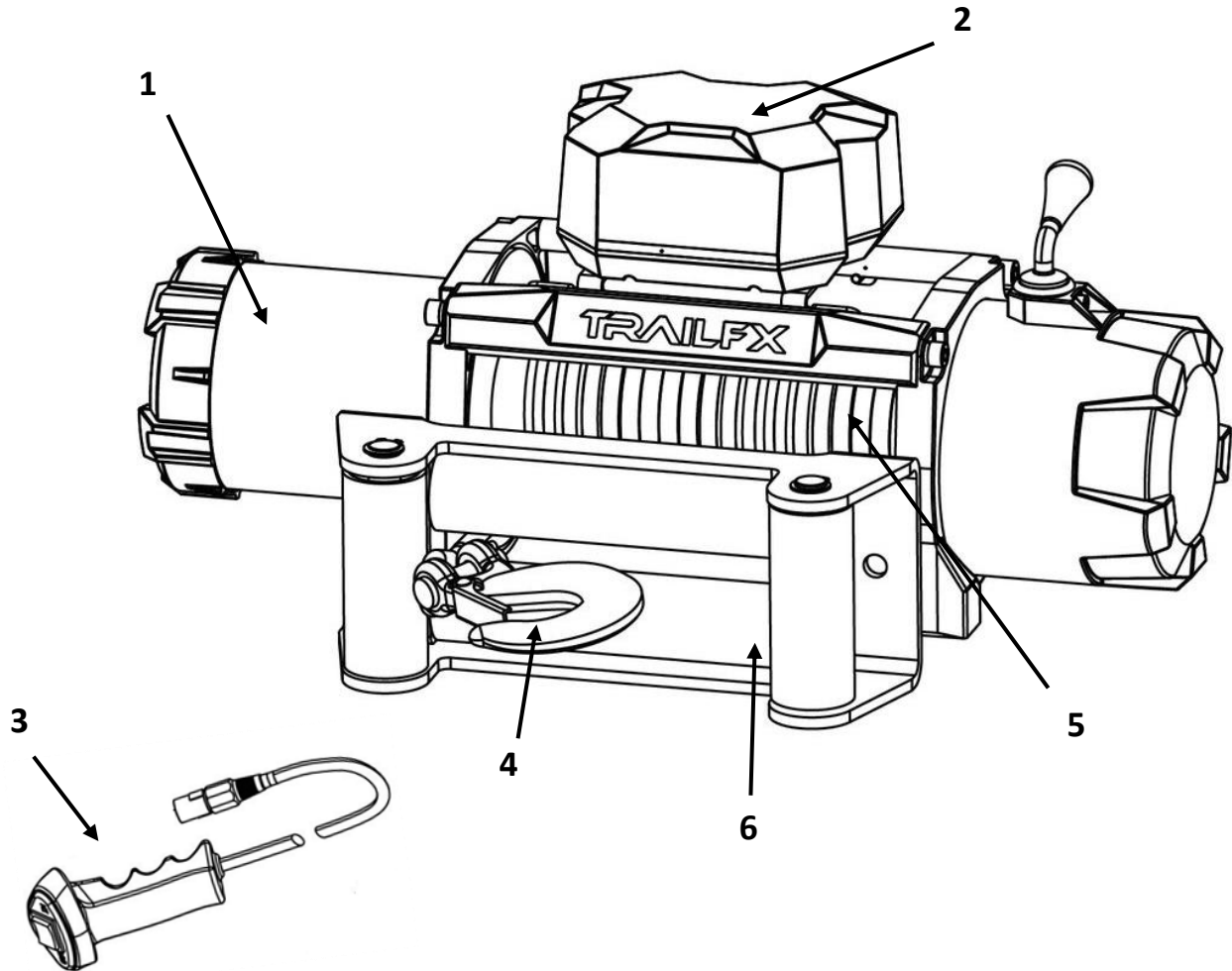







# Replacement Parts - WXV95B



Replacement Parts		
Item #	Description	Part Number
1	Motor Assembly	WXV001
2	Control Box	WXV002
3	Remote Control	WXV004
4	Clevis Hook	WXV005
5	Wire Rope	WA006
6	Roller Fairlead	WA008
N/P	Solenoid (Inside Control Box)	WXV003
N/P	Battery Cable	WXV006
N/P	Hook Strap	WA010
N/P	Mounting Hardware	WA012

N/P – Not Pictured

# Winch Accessories List

Product No / Description	Product Images		Product Features
<b>WA014</b> TrailFX Accessory Kit	 		<ul style="list-style-type: none"> <li>* Tree Trunk Protector</li> <li>* Snatch Block</li> <li>* 3/4" D-Ring (2)</li> <li>* Pair Orange Gloves</li> <li>* Recovery Choker Chain</li> <li>* Recovery Strap</li> </ul>
<b>WA015</b> TrailFX Winch Gloves	 		<ul style="list-style-type: none"> <li>* Extra Large</li> <li>* Winch Gloves</li> <li>* Orange/Black</li> </ul>
<b>WA016</b> TrailFX Winch Cover	 		<ul style="list-style-type: none"> <li>* Winch Cover</li> <li>* For TrailFX Winches</li> <li>* Black with TrailFX Logo</li> </ul>
<b>WA017</b> TrailFX Winch Mounting Plate - Universal	 		<ul style="list-style-type: none"> <li>* Winch mount</li> <li>* Load Range between 8000lb to 12000lb</li> <li>* Flat, Fixed Mount</li> <li>* Textured Black Powder Coat</li> </ul>
<b>WA018</b> TrailFX Winch Mounting Plate - Cradle	 		<ul style="list-style-type: none"> <li>* Winch mount</li> <li>* Load Range between 8000lb to 12000lb</li> <li>* 2" Receiver Mount</li> <li>* Textured Black Powder Coat</li> </ul>

# Warranty Terms:

## Limited Lifetime Warranty for Mechanical Components

## Limited Three (3) Year Warranty for Electrical Components

TrailFX and Keystone Automotive Operations Inc. make no guarantees or warranties for products not manufactured by Keystone Automotive Operations Inc. Such products are covered solely under any applicable warranty of the manufacturer. It is always recommended that the operating instructions and warranty instructions provided by the manufacturer are followed.

Keystone Automotive Operations Inc. warrants its products to be free from manufacturing and material defects to the original purchaser for the length of warranty stated above from the date of retail purchase. If any products are found to have a manufacturing or material defect, the product will be replaced or repaired at the option of TrailFX and Keystone Automotive Operations Inc. with proof of purchase by the original purchaser. The original purchaser shall pay all transportation and shipping costs associated with the return of the defective product and the defective product shall become the property of Keystone Automotive Operations Inc.

The Warranty applies to Keystone Automotive Operations Inc. products used for individual and recreational purposes. Commercial usage of the Keystone Automotive Operations Inc. products limits the warranty to 90-days from date of purchase.

The Warranty applies only to Keystone Automotive Operations Inc. products which are found to be defective in manufacturing or material. This warranty does not apply to normal wear and tear of the finish placed on Keystone Automotive Operations Inc. products.

TrailFX and Keystone Automotive Operations Inc. are not responsible for any labor costs incurred for removal or replacement of the defective product.

TrailFX and Keystone Automotive Operations Inc. are not responsible for repair or replacement of any product under the limited warranty where the product was improperly installed, misapplied, altered, abused, neglected, overloaded, misused or damaged as a result of an accident, including any use of the product not in accordance with all product operating and safety instructions.

Without limiting the generality of the foregoing, TrailFX and Keystone Automotive Operations Inc. shall under no circumstances be liable for any incidental or consequential loss or damage whatsoever arising out of, or in any way relating to any such breach of warranty or claimed defect in, or non-performance of the products. Some states do not allow the exclusion or limitation of incidental or consequential damages, so the above exclusion or limitation may not apply to you.

This limited warranty gives you specific legal rights, and you may also have other rights that vary from state to state.