

2016-20XX, TOYOTA, TACOMA

FRONT BUMPER INSTALLATION INSTRUCTIONS

THIS BUMPER SHOULD ONLY BE INSTALLED BY A PROFESSIONAL.



SAFETY

Know safety, no injury. Know injury, no safety. ~Author Unknown

If there are any questions, call 1-855-HHTOUGH

- **READ ALL SAFETY INSTRUCTIONS BEFORE INSTALLATION**
 - FOLLOW ALL INSTRUCTIONS FOR PROPER ASSEMBLY
 - WEAR APPROPRIATE EYE PROTECTION
 - EXERCISE CARE WHEN LIFTING COMPONENTS
 - USE APPROPRIATE TORQUE FOR BOLTS

SUGGESTED TORQUE VALUES FOR STEEL GRADE SAE 5 BOLTS

BOLT DIAMETER (INCH)	TREADS PER INCH	TORQUE (POUND-FEET)
1/4	20	7
5/16	18	14
3/8	16	25
7/16	14	40
1/2	13	60
9/16	12	88
5/8	11	120
3/4	10	200
7/8	9	302
1	8	466

I. PARTS LIST

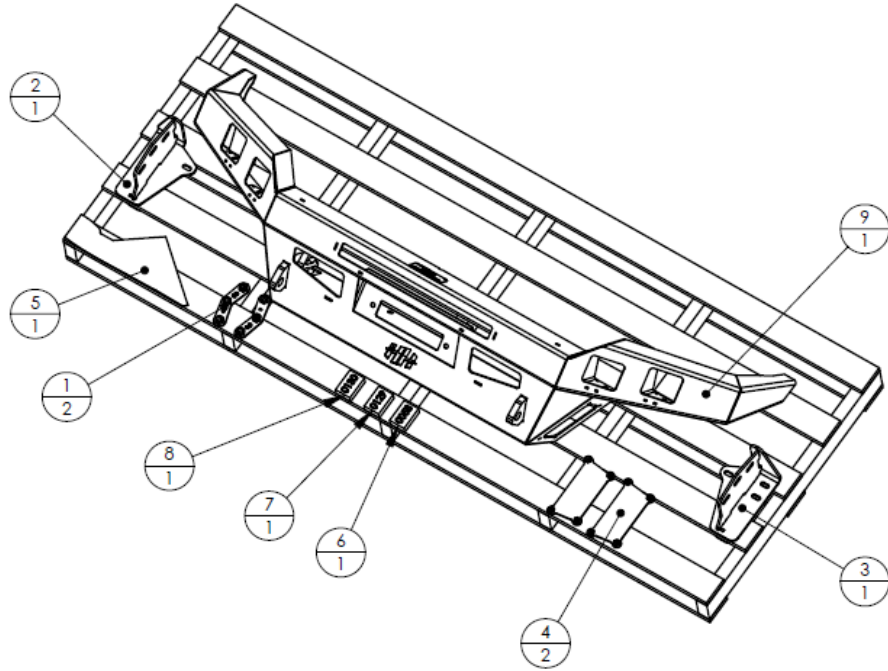

ITEM NO.	QTY.	PART NUMBER	DESCRIPTION
1	2	601-56-2868	WELDNUT TAB 3
2	1	601-56-4083	RIGHT FRAME MOUNT WELDMENT
3	1	601-56-4084	LEFT FRAME MOUNT WELDMENT
4	2	601-56-4085	COVER PLATE WELDMENT
5	1	601-56-4092	FENDER CUT TEMPLATE
6	1	60K-56-0058	HARDWARE KIT #58
7	1	60K-56-0129	HARDWARE KIT #129
8	1	60K-56-0130	HARDWARE KIT #130
9	1	60P-56-0840	600-56-0840 POLISHED

II. TOOL LIST

1. Basic tool set
2. Blue masking tape
3. Fine tip permanent marker
4. 4" electric grinder with cutoff wheel or air die grinder with cutoff wheel
5. Scissors (don't run with them)
6. Small handsaw
7. 10mm socket
8. 14mm socket
9. 17mm socket
10. Universal joint for socket
11. 12" extension



2016-20XX, TOYOTA, TACOMA

12. Trim tool
13. Face shield
14. Safety glasses
15. Ear plugs
16. Gloves
17. ¾" socket

III. CUTTING OE BUMPER UNDER HEADLIGHTS

1. Using 10mm socket, remove six screws attaching fender flares to vehicle. (both sides)



2. Starting at the front of the truck, gently pull out on the fender flare to disengage the plastic clips. You will need easy access to the OE bumper under the flare. You can remove the entire flare if you want.
3. Using blue painters tape, mask off headlight and area under headlight. You need to leave a small gap where the plastic bumper meets the metal fender. This will allow you to align the cut template.





2016-20XX, TOYOTA, TACOMA

- Using provided metal template and a marker; trace the perimeter onto a piece of paper.
- Using scissors, cut out template for marking the cut line on OE bumper.

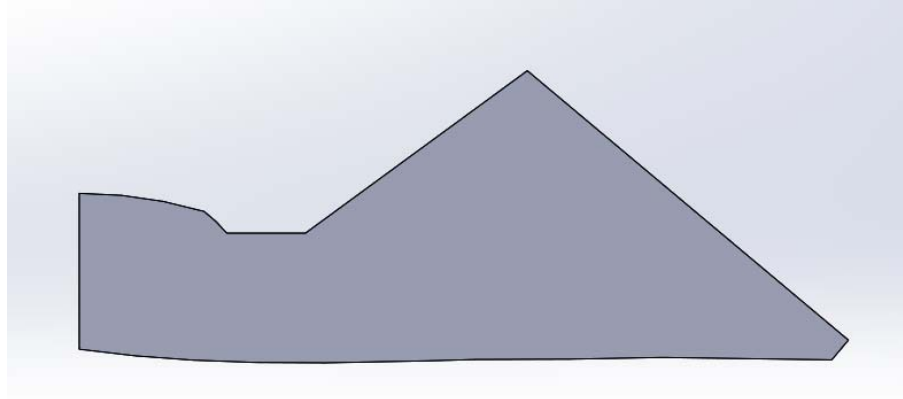

- Align template to line where plastic OE bumper and metal fender meet. Use some tape to keep it in place while you trace the bottom of the template with a permanent marker. After tracing the final cut line, measure down $\frac{3}{16}$ " and make another line for your initial cut line.

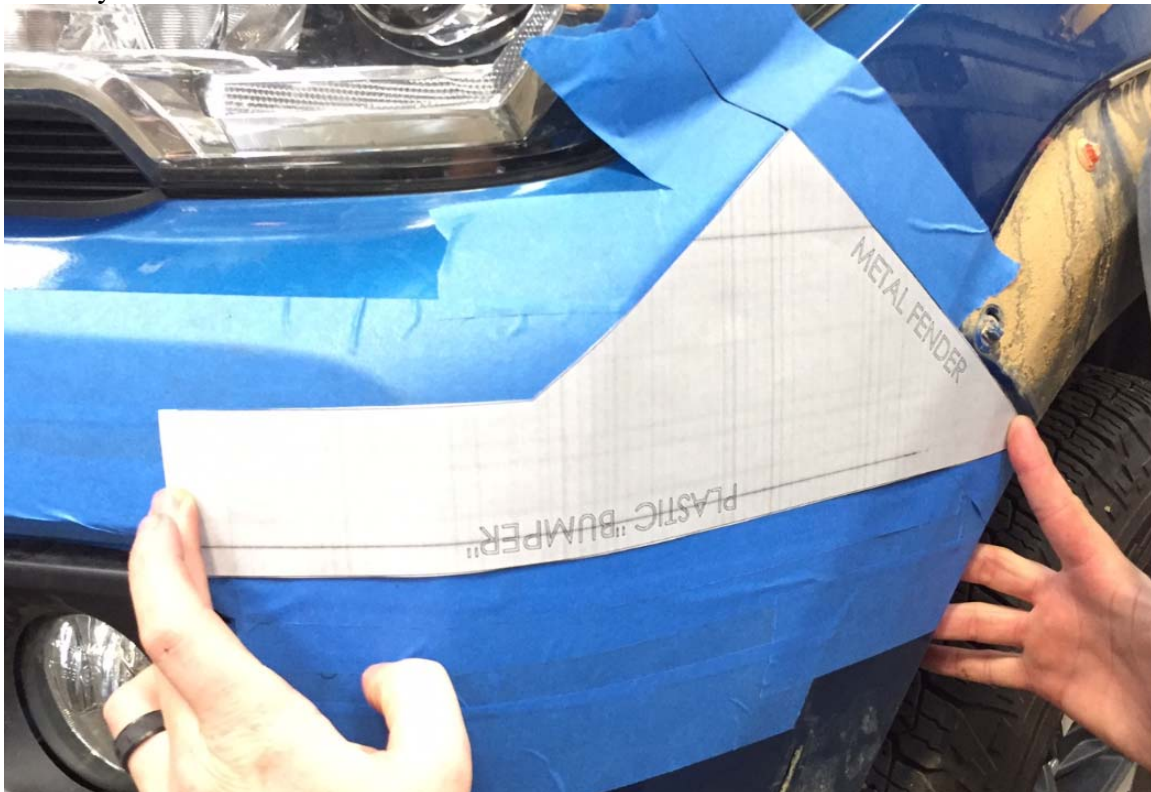

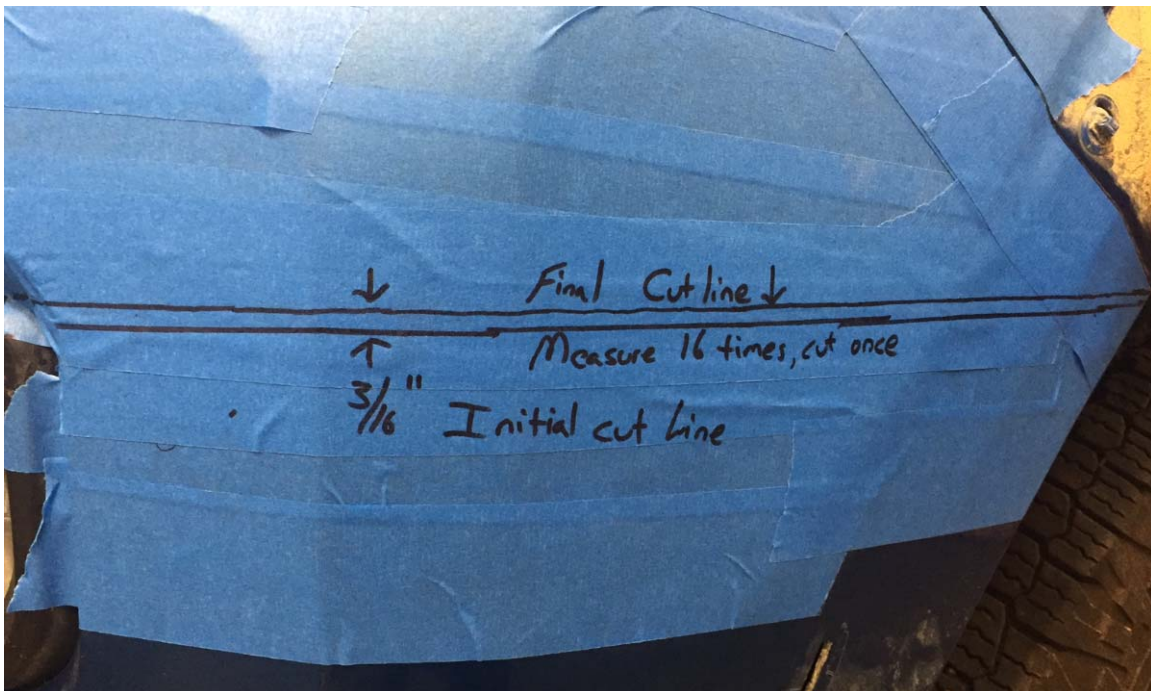

7. Put on safety glasses, face shield, ear plugs and gloves. Using a cutoff wheel on a electric grinder or air die grinder, cut initial line. This will separate the bottom of the bumper side from the top. Do not allow the cutoff wheel to go more than 1/8" deeper than the plastic bumper. This could damage the metal fender or plastic retainer clip near the tire. The bottom of plastic retainer clip will be cut off after the OE bumper is removed.

8. Using 10mm socket, remove two screws attaching middle of grill to truck.

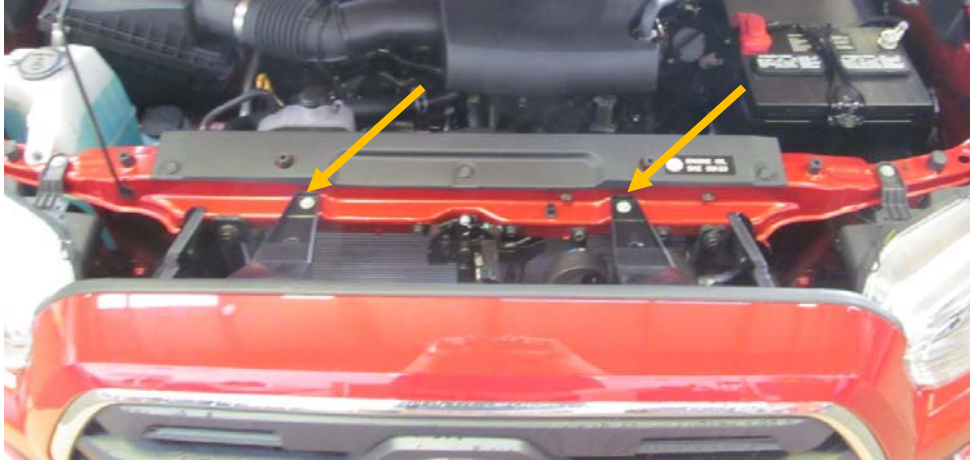

9. Using trim tool, remove two plastic clips attaching grill to headlights. NOTE: Pry up on center of clip.



10. Gently pull out on grill near headlight to release plastic tabs. (both sides) Set grill aside; It will be reused.
NOTE: Hold grill with both hands, it will pop off when tabs are released.





2016-20XX, TOYOTA, TACOMA

11. Using 10mm socket, remove six screws attaching bottom of OE bumper to truck.
Two are in the center, and two are in each side.



12. Unplug OE fog lights. Plug is located in center of truck where the bottom of the grill was.





2016-20XX, TOYOTA, TACOMA

- Using trim tool, remove six plastic clips attaching top center of plastic bumper to truck. Remove plastic bumper from truck.



- Disengage all clips attaching black plastic piece in center of bumper. Remove center piece and fog light wiring harness.
- Using small hand saw (see pic below), remove any extra material attaching bumper outs to center portion. When you are done, you will only need the small outer portions.



- Using small hand saw, remove the small pieces of the plastic retainer clip that were left on in step 7. You should have a line to follow from the bumper cut. NOTE: Use your paper template as a guide.
- Replace outer portions of stock bumper on truck. Do not trim OE fender flares at this time.





2016-20XX, TOYOTA, TACOMA

18. Remove black plastic energy absorbing bumpers from OE crash bar.



19. Using 14mm socket, remove six bolts attaching OE crash bar to frame. (three per side)
Remove OE crash bar. NOTE: If you can't get the bar off, loosen three bolts on one side of the crash bar extrusion.

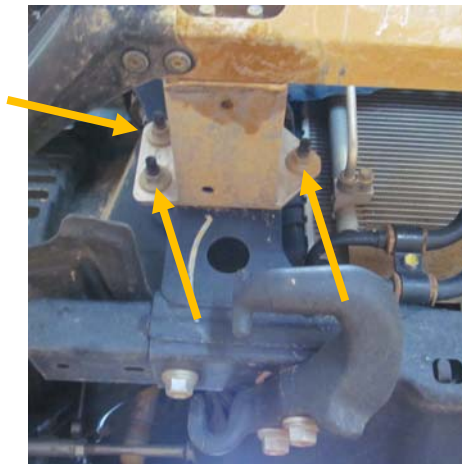

20. Using 17mm socket, remove two bolts attaching OE tow hook to frame. Remove hook.
Remove one bolt attaching fender extension to frame. (both sides) Remove fender extensions.

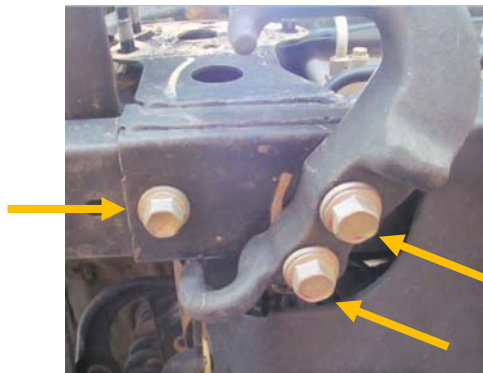



2016-20XX, TOYOTA, TACOMA

21. Using scissors, cut inner fenders by following arrows below. Remove lower portion of inner fenders.



IV. INSTALLATION OF HAMMERHEAD BUMPER

1. Install lights and winch using manufacturer's instructions and hardware.
2. Lay out HH frame mounts, hardware kit #130 and OE hardware as shown.



3. Attach HH frame mounts to truck frame with OE hardware. Do not fully tighten.





2016-20XX, TOYOTA, TACOMA

4. Install carriage bolts from hardware kit #130 in bottom holes of HH frame mounts. Use a flat washer, lock washer and, nut on the inside of the frame. Do not fully tighten.
5. Layout weldnut tabs and hardware kit #58 as shown.



6. Using a hoist or a few friends, attach bumper to frame mounts using hardware. Install weldnut tabs through the square cutouts in the bottom of the bumper and install the bolts from the outside. Use one 1/2"-13x2" bolt, one 1/2" flat washer, and one 1/2" lock washer per hole. Start all bolts before aligning bumper. Align bumper a minimum of 1/4" below OE bumper. When truck flexes off-road, this distance allows your bumper and body to have clearance. Tighten bolts with 3/4" socket and a 12" extension. Tighten frame mount bolts at this time.
7. Trim fender flares to match OE bumper.
8. Using hardware from kit # 129 and a T40 torx bit, install cover plate weldments (in blue below) on bottom sides of bumper. Slide them in through the cutout in the bumper, and insert bolts in weld nuts. These plates can be painted to accent your truck's color if you wish.

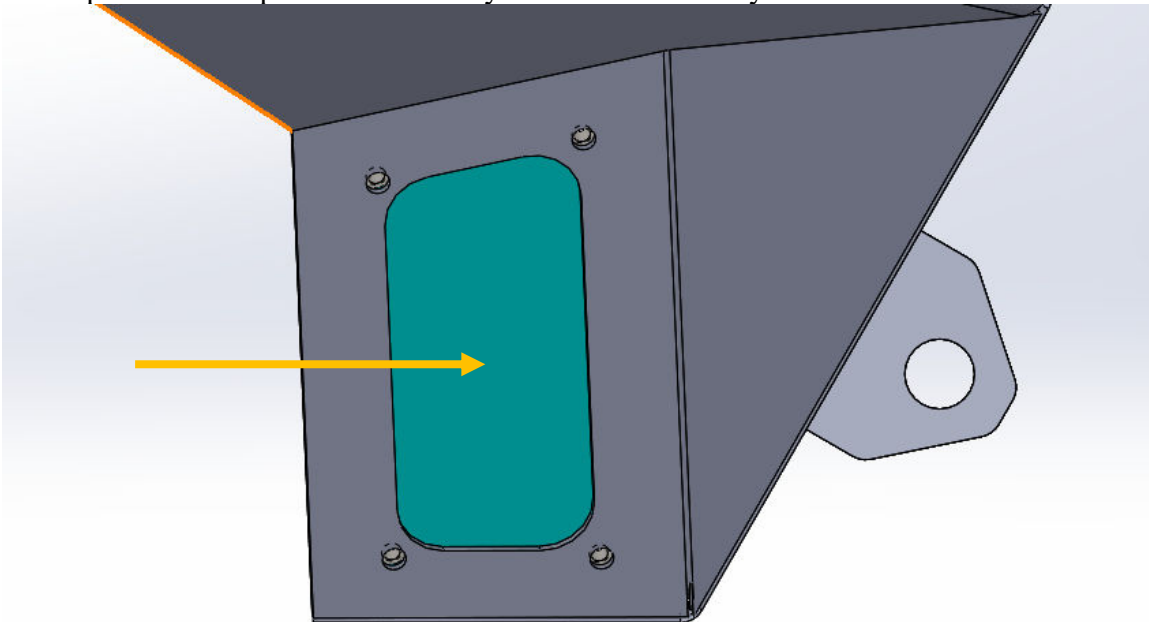



2016-20XX, TOYOTA, TACOMA



Congratulations! Your bumper installation is now complete.
Thank you for your purchase.